

OPERATION MANUAL

Before attempting to operate this machine, read and fully understand the contents of this Operation Manual. Make yourself familiar with safety instructions, controls, servicing and maintenance of the machine. Operators must also read through the engine manual which is separately provided by the engine manufacturer.

ORIGINAL INSTRUCTIONS

— WOOD CHIPPER ES151GH/GHB —



INTRODUCTION

To operate this machine most comfortably and effectively, it is essential for you to perform daily checks and regular inspection, servicing and maintenance jobs. This can be likened to your medical check-up. To keep the machine in optimum condition at all times and prevent accident and injury, carry out daily checks and servicing on a routine basis.

Take care of detecting even a small problem in the early stage before it becomes a big problem. If you have some problem with the machine, do not put the machine into operation. Please feel free to contact and consult the dealer from whom you purchased the machine to solve the problem.

When notifying the dealer, please report MODEL NUMBER and SERIAL NUMBER of the machine,

For the purpose of product improvement, specifications including spare parts may change without prior notice.

CONTENTS

SAFETY INSTRUCTIONS	1
DECALS	2
USE OF THIS MACHINE AND SPECIFICATIONS	12
NAME OF THE COMPONENT PARTS	13
PRE-OPERATING CHECKLISTS	14
HOW TO OPERATE MACHINE	16
STARTING THE ENGINE	16
HOW TO DRIVE THE MACHINE	17
HOW TO STOP THE MACHINE	17
ADJUSTING THE THROTTLE	18
TURNING THE MACHINE	18
LOADING, UNLOADING & SLOPES	19
HOISTING THE MACHINE	20
POSITION THE SHOOTER	21
POSITION THE LOW DISPATCH UNIT	21
16 ROTOR CLUTCH	22
17 FEED SWITCH	23
17 FEED MODE SWITCH	23
18 FEED ROLLER SAFETY BAR	24
18 FLOW CONTROLLER	25
19 FEED ROLLER CLOGGING PREVENTION ..	25
20 CHANGING SCREENS	26
21 START CHIPPING WORK OPERATIONS ..	26
21 FEED ROLLER CLOGGING RELEASE	27
REGULAR MAINTENANCE	28
KNIFE BASICS	28
REMOVE & AFFIX KNIVES	29
KNIFE ADJUSTMENT	30
REMOVE & AFFIX SHREDDER KNIVES ..	32
RE-FUELING	33
TRANSPORT CLUTCH ADJUSTMENT ..	36
28 TURNING CONTROLL LEVER ADJUSTMENT ..	36
29 PARKING BRAKE	37
30 ROTOR CLUTCH	38
32 RUBBER CRAWLER	40
33 BATTERY	41
36 ENGINE	43
LUBRICATION CHART	46
TRACK ROLLER GREASING INSTRUCTION	48
TIGHTENING NUTS & BOLTS	50
SERVICING AFTER OPERATION/LONG TERM STORAGE	51
SERVICING AFTER OPERATION	51
LONG TERM STORAGE	52
51 ACCESSORY TOOL LIST	53
LIST OF THE CONSUMABLE PARTS	54
TROUBLESHOOTING	55
MAINTENANCE SCHEDULE	57
NOISE TEST	58
MACHINE DIMENSIONS	59
58 HYDRAULICS DIAGRAM	60
59 ELECTRONIC WIRING DIAGRAM	61
CE DECLARATION OF CONFORMITY	62
WARRANTY STATEMENT	63
JUST IN CASE OF EMERGENCY	64

SAFETY INSTRUCTIONS

CAUTION

1. This operation manual must be retained within easy access of operators. Operators must be careful not to lose or damage the operation manual.
2. If the operation manual is missing or illegible due to damage, obtain new one from our dealers and retain it within easy access.
3. If the machine discussed in this operation manual is rented, be sure to provide the manual with the machine. Let the renter read and understand the manual. Give new operators proper instructions and training before they start operating the machine.
4. If the machine is transferred to other people, make sure that this operation manual is provided with the machine.

CAUTION

1. Operators of this machine must read and understand the contents of this operation manual before attempting to operate it.
2. If safety decals are torn and illegible, obtain new ones from our dealers and replace them.

1. Read through this operation manual and make yourself familiar with the operation, servicing and maintenance of this machine before use.
2. Never operate the machines without repairing or replacing the deformed or defective parts.
3. Never alter or modify this machine.
4. The machine cannot be towed on crawlers on a public road. Extended towing on crawlers will damage machine.
5. If towing very short distances on crawlers at no more than allowable top speed of gear in use, always tow using a vehicle with enough driving and braking force. Be very careful on slopes.
6. When a machine is loaded/unloaded on/from truck or trailer for transport, stop the truck on a level surface, engage the truck's parking brake, and position it securely with wheel stoppers. Extreme caution must be taken not to topple the machine from the ramps or truck. (refer "**Loading, Unloading & Slopes**").



7. Never operate the machine alone. This machine must be operated by two or more operators.
8. Never attempt to touch the muffler and surroundings during operation because it becomes very hot.
9. Don't directly touch the feed roller or its attaching portions.
10. Do not insert your fingers into the shooter or low dispatch unit. Your hands might be caught in the rotor and this could cause serious injury.
11. Gasoline is extremely flammable. Extreme caution must be taken when handling the fuel.
 - (1) Use only fresh, clean gasoline.
 - (2) Use an approved fuel container for the fuel tank. Fuel container's outlet must fit the fuel tank's inlet. Check to see if these ports fit. If not, use a suitable fuel pump.
 - (3) Do not remove the fuel tank cap or add fuel while the engine is running or hot.
 - (4) Do not fill the fuel tank indoors.
 - (5) Wipe off any spilled fuel.
 - (6) Do not use gasoline as a cleaning fluid.
 - (7) Never smoke while handling gasoline.
 - (8) Do not handle fuel near a naked flame or uncovered electric light.
 - (9) Keep the fuel container away from open flames and equipment that may spark.
12. Wait until the machine has cooled before storing indoors and remove key.
13. When performing maintenance with two or more people stay aware of each others location by talking to avoid accidents.
14. Remove chips or other material in and around the crawlers as this could cause transmission troubles.
15. Never perform chipping operations inside a building.

DECALS

Before attempting to operate the machine, read these decals and fully understand the instructions and meaning. If any decal is worn, damaged, illegible or missing, obtain new one from our dealers. Safety decals must be placed to their proper location as indicated below. For locations of other decals, see the following photographs and illustrations and affix them to their respective places. Keep all decals always legible.

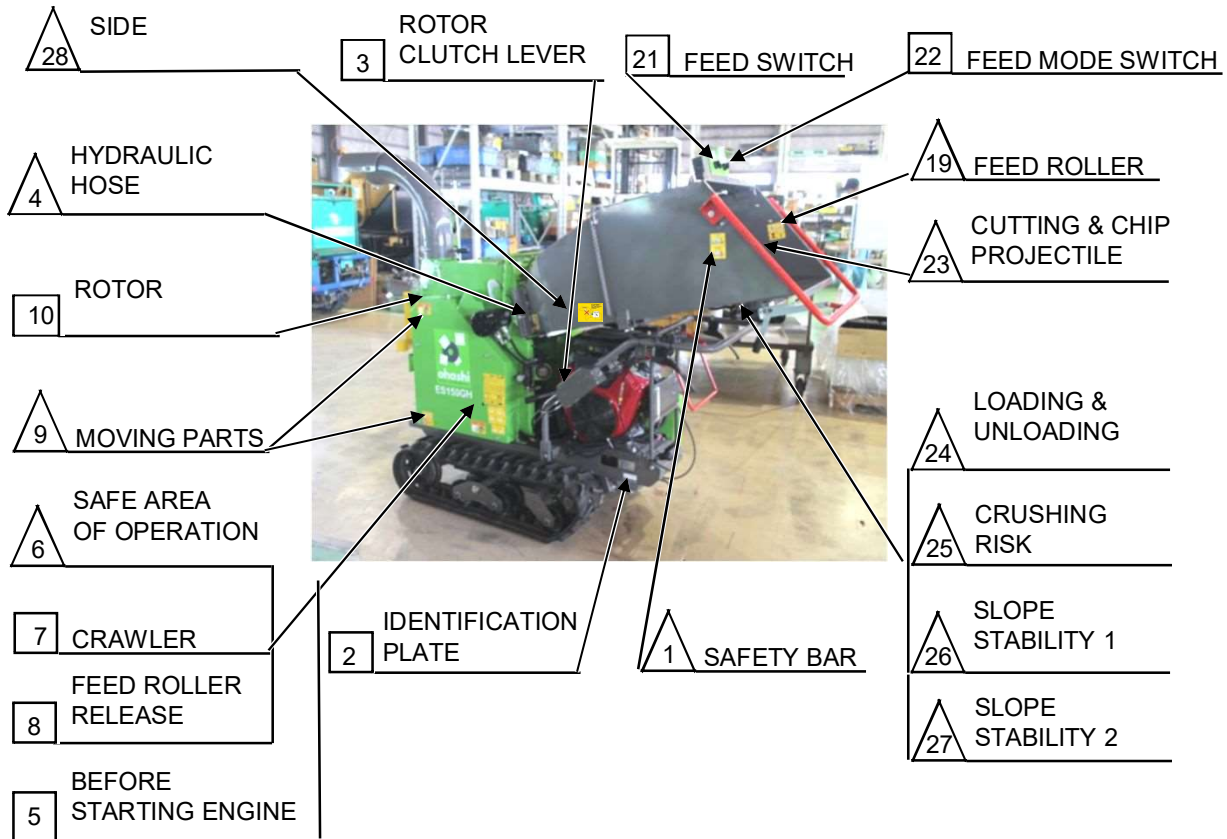
Location of SAFETY decals



-  SAFETY DECAL
-  INSTRUCTION DECAL

DECALS

Before attempting to operate the machine, read these decals and fully understand the instructions and meaning. If any decal is worn, damaged, illegible or missing, obtain new one from our dealers. Safety decals must be placed to their proper location as indicated below. For locations of other decals, see the following photographs and illustrations and affix them to their respective places. Keep all decals always legible.

Location of SAFETY decals



DECALS

1 SAFETY BAR

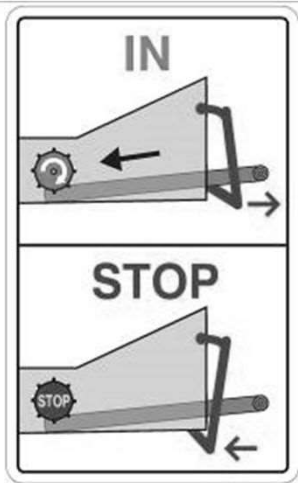

The safety bar operates to stop the feed roller in the case of an emergency.

Pull the safety bar out to activate the feed roller so that feed material is pulled into the machine.

Push the safety bar in to de-activate the feed roller so that the feed roller no longer move.

2 IDENTIFICATION PLATE



The details of Ohashi inc., the CE mark and the specific details of the machine purchased.

3 ROTOR

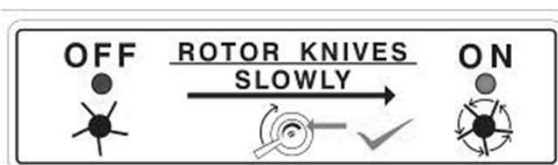

The rotor clutch lever activates the rotor.

Pull the rotor clutch lever from OFF to ON slowly. Ensure the throttle is at full. Pause between OFF and ON so that the rotor clutch engages.

DECALS

4 HYDRAULIC

The hydraulic hoses are dangerous and should not be touched.



Do not touch the hydraulic hoses and their connections to the hydraulic pump, hydraulic motor and hydraulic tank.

Refer to "**Re-fueling**" section in this user manual for more safety information.

5 BEFORE

Before starting the engine perform the following to maintain the machine in good condition.

ATTENTION	
(E) Before starting engine, refer to user manual and check lists	
(F) Avant de démarrer la machine, veuillez vous référer au manuel de l'utilisateur et aux listes de vérifications	
(D) Vor dem Starten des Motors, bitte lesen Sie das Handbuch und die Checklisten	
(ES) Antes de prender el motor por favor lee el manual y las listas de verificación	
(IT) Prima di accendere il motore, leggere attentamente le istruzioni di funzionamento e controllare le liste di sicurezza del manuale utente	
(NO) Før du starter motoren, se bruksanvisningen og sjekklistene	
(GR) Πριν την εκκίνηση του κινητήρα, αναφέρετε στο γυμνάσιο χρήσης και στην λίστα ελέγχου	
(SV) Innan du startar motorn, se användarhandboken och checklistor	
① ENGINE OIL 	② AIL CLEANER
③ KNIFE BOLTS 	④ GREASE

As well as reading the user manual and checklists before starting the engine users must especially take care of the following 4 points to maintain the machine in good condition and prevent damage to the machine.

DECALS

6 SAFE AREA

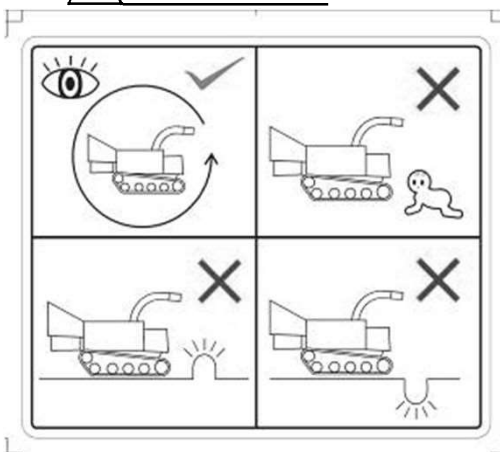

The area around the machine should be checked thoroughly before operating the machine.

Check around the machine before use. Check for things you may not see from the operators control area.

Be careful not to damage the crawlers or the transmission by driving into holes or over obstacles.

7 CRAWLER

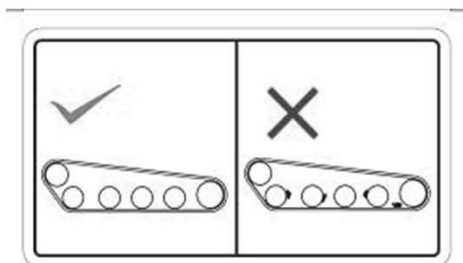

The crawlers and the area between the crawler wheels should be kept clean and free of materials.

Be sure to clear the crawlers from any materials as this may damage the transmission.

8 FEED ROLLER

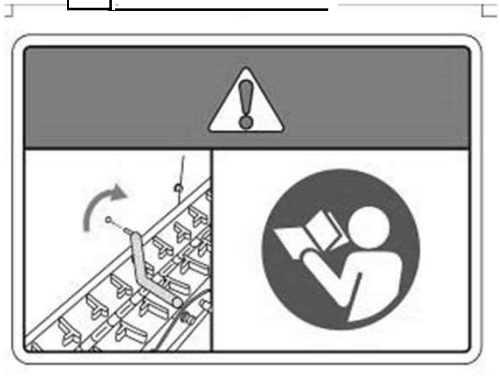

The feed roller can be rotated manually if it becomes clogged.

Refer to "**Feed Roller Clogging Release**" section in this user manual for further instructions.

9 MOVING PARTS

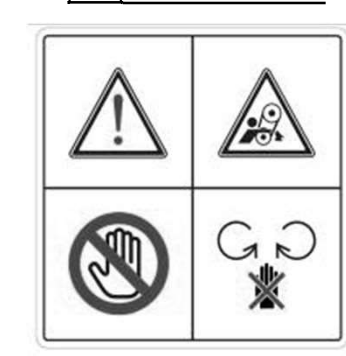

Moving parts of the engine and machine are dangerous and may cause injury.

Engine belts and other moving parts of the engine and machine can cause injury if touched during motion.

Do not attempt to remove covers while the machine is running or moving parts are moving.

DECALS

10 ROTOR

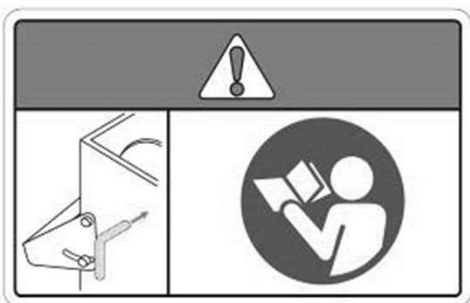

The rotor lock pin can be used to secure the rotor reducing the risk of injury from rotating knives.

When performing maintenance on the rotor, on the knives or when clearing out the rotor the rotor lock pin can be used to prevent injury from rotating knives.

Refer to "**Remove & Affix Knives - Chipper Knives**" in this user manual for further instructions.

11 HOISTING POINT



The hoisting point can be used to lift up the machine to perform maintenance and inspections

Refer to "**Hoisting the Machine**" section in this user manual for further instructions.

12 FEED BOX



The feed box when in motion can be dangerous and cause injury.

The feed roller when activated can move up and down creating movement of the feed box. This movement can cause injury so therefore do not approach or put your hands or body near the feed box when the machine is operating.

13 SHOOTER



The shooter dispatches wood chips at a fast speed and may cause injury if the chips hit a person.

Before operating the machine check that the area around the machine is clear of persons and especially around where the chips are dispatched from the machine.

DECALS

14 CUTTING PARTS

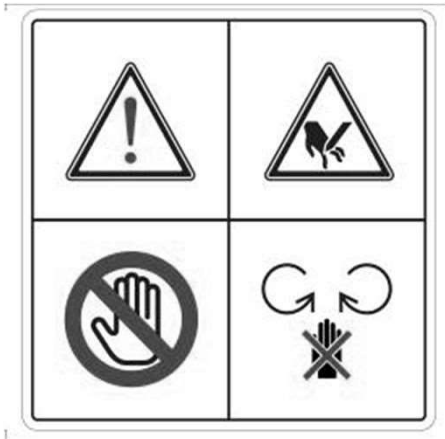

Moving parts here will cut flesh and cause serious injury if touched by a persons hands or other body parts.

Do not remove safety covers while the engine is on or moving parts have not yet stopped.

15 MUFFLER



The muffler is hot during and after operation. Do not touch or a burn injury may occur.

Even after use the muffler may remain hot. Wait until the machine cools down before making any contact with the muffler.

16 BRAKE HANDLE



The brake handle activates the transmission and initiates the movement of the machine.

To initiate the movement of the machine pull the brake handle up and keep it up.

To stop the movement of the machine let go of the brake handle and let it drop to the lower position.

DECALS

17 SAFETY WEAR



Read the user manual, and wear helmet, ear protectors, eye protectors, gloves and non-sag clothing before using the machine.

18 SOUND LABELS



Sound labels display the sound levels which users are likely to be exposed to.

Users must use ear protection equipment when operating this machine and must insist other people close to the machine also wear ear protectors.

19 FEED ROLLER

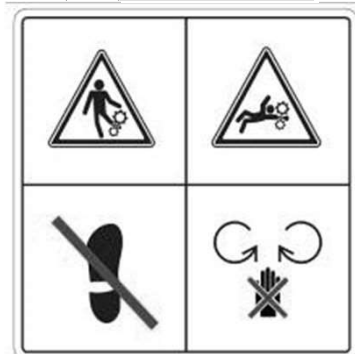

If caught in the feed roller serious injury will occur.

Do not place your hands, feet or any other body part near the feed rollers.

Do not attempt to climb into or on the lower edge of the hopper or you may be caught in the feed roller.

20 FEED MATERIALS

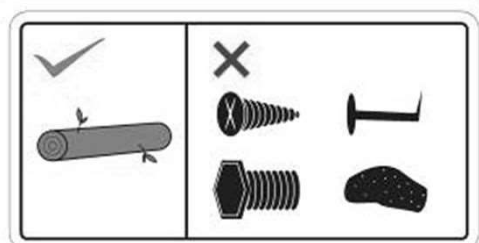

The machine is only designed to chip organic material like wood.

Do not place sand, dirt, metal, stones, plastic, rope, clothing, cardboard, books, newspapers rubber, glass or any other non-wood material into the hopper to be chipped or damage will occur to the machine.

DECALS

21 FEED SWITCH

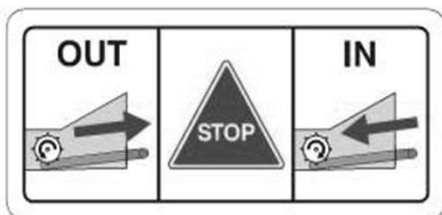

The feed switch controls the movement of the feed roller.

Move the switch to OUT to reverse the direction of the feed roller so that material is ejected out of the hopper. Move the switch to the STOP area to stop the feed roller movement. Move the switch to IN to activate the feed roller to pull materials into the rotor.

22 FEED MODE SWITCH

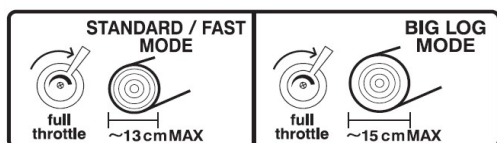

The feed mode switch allows the user to match and optimize the feeding settings to the material being chipped.

Move the switch to "STANDARD / FAST MODE" for the fastest chipping of branches no larger than 13cm wide. Move the switch to "BIG LOG MODE" to if branches are 14cm or greater wide. Feed speed may reduce.

23 CUTTING & CHIP

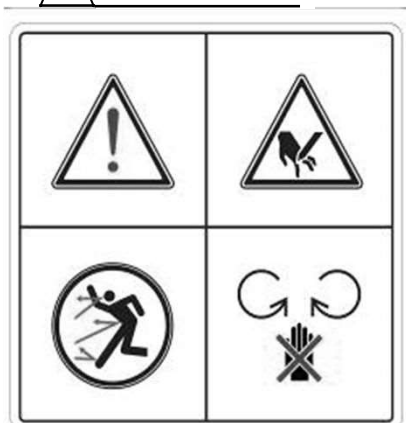

Moving parts may cut flesh and cause serious injury. Feed material occasionally projected out of the hopper can cause injury.

Do not place hands or body parts near the area where moving parts may cut flesh and cause injury. Do not remove covers while the machine is on or moving parts have not stopped.

Do not stand in front of the hopper while the machine is processing feed material. Stand to the side to avoid being struck by feed material that occasionally projects out of the hopper.

24 LOADING &

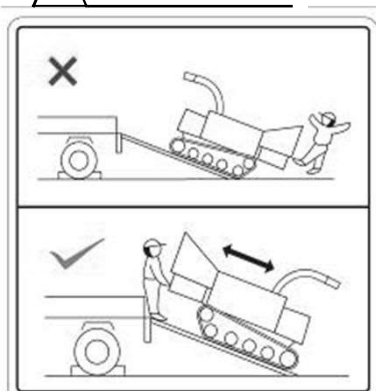

Load and unload the machine in the correct manner or injury may occur.

When loading or unloading the machine onto a truck, trailer, van or higher platform using ramps do not stand on the downward side of the machine. Always stand upward from the machine in the higher position so that if the machine rolls or tumbles you are in a safe position.

DECALS

25 CRUSHING



Be careful to avoid being crushed by the machine.

Be careful not to have your feet or other body parts crushed under the moving crawlers.

Be careful not to be crushed while driving the machine between the machine and another object.

Be careful not to drive the machine at a dangerous speed on a slope or on a slope which is too steep or the machine may tip and crush you.

26 SLOPE

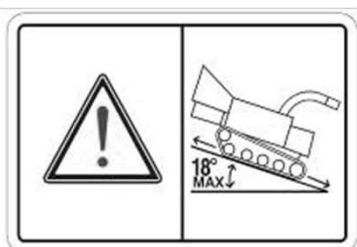

Only drive the machine up/down a slope of 18° or less.

When unloading or loading or when driving the machine anywhere do not drive the machine on a slope of more than 18° in a straight up or down direction on the slope.

27 SLOPE

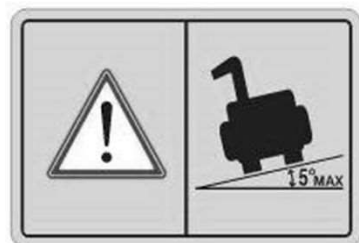

Only drive the machine across a slope of 5° or less.

When unloading or loading or when driving the machine anywhere do not drive the machine on a slope of more than 5° in a horizontal across direction along the slope.

28 SIDE

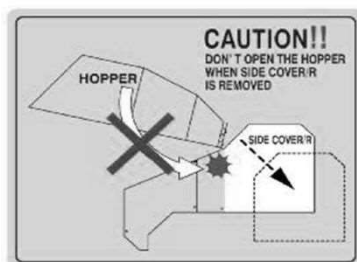

When removing the Side Cover R, be careful not to damage the Side Cover E1

When removing Side Cover R, please also remove Side Cover E1 if opening the hopper.

Not doing so may result in damage to Side Cover E1 if the hopper is swung open.

USE OF THIS MACHINE AND SPECIFICATIONS

USE OF THIS MACHINE

This operating machine is designed to chip / shred wood and other similar organic materials. Make sure before chipping that no materials such as soil, sand, stones, metals, bottles etc. are contained in the woods.

Do not use the machine in any other way than its intended use.

SPECIFICATIONS

Description	Wood chipper / shredder
Model No.	ES151GH / GHB
Overall LengthxWidthxHeight (mm)	In use - 2420x720x1560 In transport - 1650x720x1610
Weight (kg)	490
Drive	Belt clutch, V-belt
Max. diameter of wood treated (mm)	150 (soft wood)
Cutting	2 chipper knives, 1 counter knife and 8 shredder knives
Infeed dimensions (mm)	150x205
Feeding system	Independent hydraulic motor integrated with automatic no stress electronic system
Discharge system	Fan forced shooter
Height of duct (mm)	1560
Discharge angle	Adjustable in 270°
Transport system	Rubber crawler
Transport speed	Forward : 1st gear 1.2 Km/h; 2nd gear 2.5 Km/h
	Reverse : 1.4 Km/h
Engine Model	Briggs & Stratton 3864 Vanguard V-Twin
Max. output	23.3 PS / 17.1 kW
Fuel tank capacity (ℓ)	Approx. 15, Unleaded gasoline

Note: As product improvement takes place, specifications may change without prior notice.
For engine and battery, refer to respective manufacturer handling manuals.

NAME OF THE COMPONENT PARTS

See the machine with your own eyes and identify each component.

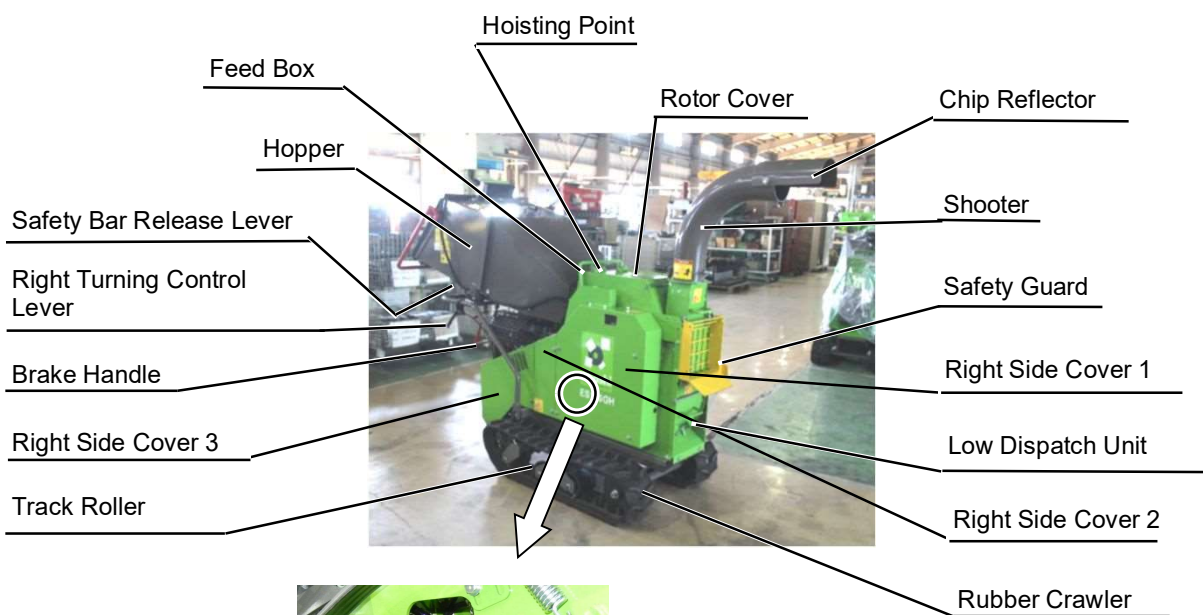

Hydraulic Tank and Pump

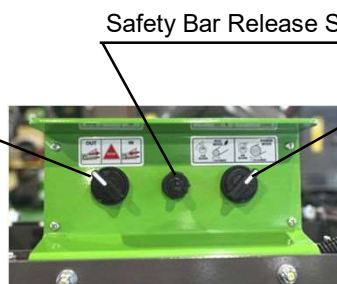

Feed Switch Safety Bar Release Switch Feed Mode Switch

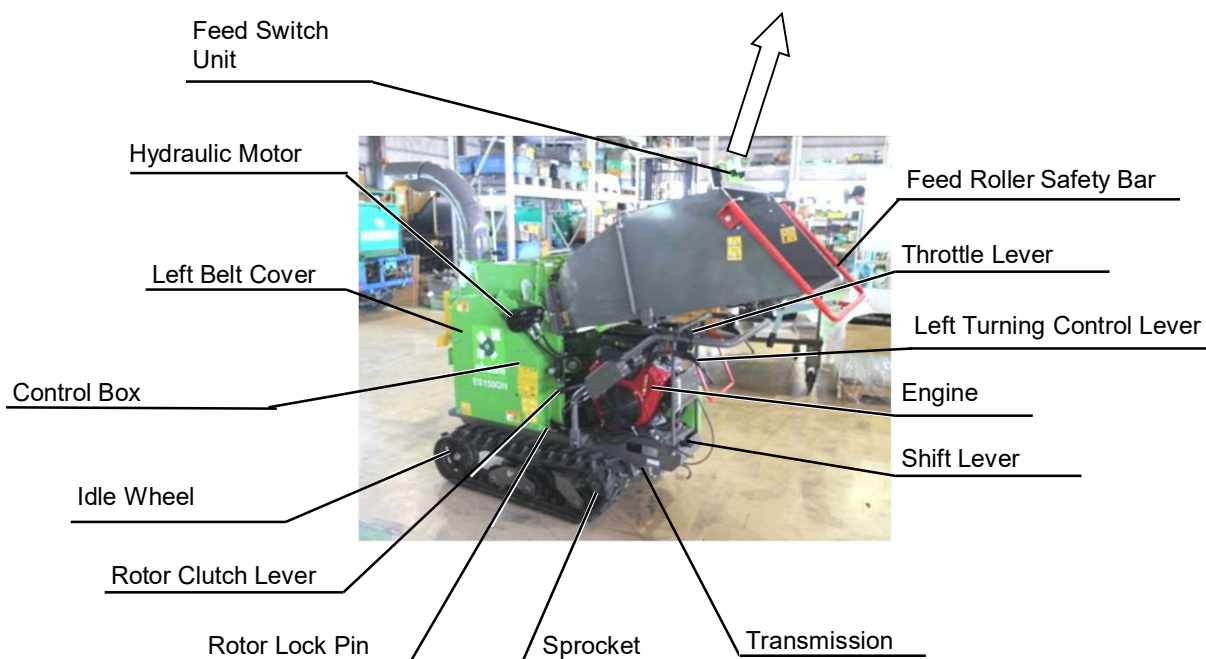

PRE-OPERATING SAFETY CHECKLIST

To prevent injuries and fire hazards, comply strictly with the following instructions.

BEFORE STARTING ENGINE AND ACTIVATING RUBBER CRAWLERS

1. All safety and operating sections of User Manual **MUST** have been read, understood and applied where applicable.
2. **CHECK** all machine safety covers, guards and housing are closed and fitted securely with securing devices, bolts, locks etc and if engine is running **DO NOT REMOVE**. Do not lose covers' nuts and bolts.
3. Walk at least once around machine to **ENSURE** there are no obstacles, people or small children near machine and / or rubber crawlers and maintain your visibility of surrounding areas at all times.
4. **ENSURE** Rotor Clutch Lever is in OFF position, Shift Lever in N Position, Feed Switch in STOP position and that Brake Handle is down moving freely and is unobstructed.
5. **ENSURE** machine is in a well ventilated, open area. Exhaust fumes are very dangerous when breathed.
6. **ENSURE** machine is located on a flat, stable area.
7. **CHECK** for fluid leaks. If found **CONSULT** User Manual or dealer to locate the source and apply a remedy.
8. **WEAR** appropriate clothing, helmet, protectors for eyes, ears and gloves for hands. Clothing **MUST** fit operator tightly. Loose clothing **MUST** be avoided as it may get caught and pull operator into machine, causing serious injury or death.
9. **NEVER** smoke while operating machine or when handling fuel for refueling or transport. **NEVER** refuel or handle fuel near open flames or uncovered electric lighting.

BEFORE OPERATING THE CHIPPING FUNCTIONS (Feed Roller and Rotor)

1. **TEST** Feed Roller Safety Bar is working properly in Emergency Stop Position and Forward Feed Roller Position. If it is not working contact your dealer to repair the bar and / or it's sensor immediately.
2. This machine is designed to chip / shred wood and similar organic material. **ENSURE** soil, sand, stones, metals, rope, glass, wires and other such non-organic man-made materials are **NOT** contained in material to be inserted for chipping / shredding.
3. **DO NOT** operate machine's chipping / shredding functions on slopes and / or inside a building.
4. **ENSURE** that no person is located close enough to the shooter / low dispatch unit to be struck by wood chips and that dispatch units are securely fixed in position so as not to move during operation.
5. **ENSURE** before chipping and switching the Rotor Clutch Lever ON, that the engine is at full throttle.

BASICS

1. **NEVER** have safety covers off or refuel with engine on, parts still moving, key in machine or machine hot.
2. **PERFORM** inspections or tests of machine in an open, flat area free of obstacles and hazards.
3. **REPLACE** all covers, guards and housing parts after any inspection is performed.
4. If you feel any strange noise / vibration in machine, **STOP** the engine and **AFTER** moving parts have stopped consult your User Manual, inspect machine and if necessary contact your dealer.
5. Before leaving machine unattended, **CONFIRM** that engine is off with key removed and all moving parts stop, the Rotor Clutch Lever and Feed Switch are in the OFF/STOP position and the Brake Handle is down.
6. **INSPECT** and clean machine parts after use.
7. **NEVER** drive up / down a slope slanting more than 18 ° or drive sideways on a slope slanting more than 5° and always stand up slope from the machine when driving.
8. **DO NOT** operate in insufficient lighting or in a situation where visibility is poor.
9. **DO NOT** operate machine if tired, sick or under the influence of drugs or alcohol.
10. **DO NOT** allow a child and / or untrained person to operate machine.
11. Where materials become caught in Feed Roller **DO NOT** remove directly with hands. **USE** a wooden broom or other such long wooden object to remove stuck material.
12. **STAND** to the side of Hopper during operation to avoid being hit by infeed materials returning irregularly.
13. **DO NOT** place hands near the Feed Box while the Feed Roller is in operation.

PRE-OPERATING MACHINE CHECKLIST

To keep machine in top working condition, comply strictly with the following instructions.

<ol style="list-style-type: none">1. CLEAN air cleaner.2. CHECK engine oil level, cleanliness and for any spillage (SE grade or above). ※13. CHECK for cracks and / or wear on the chipper knives.4. CHECK for cracks and / or wear on the counter knife.5. CHECK for cracks and / or wear on the shredder knives and that the knives axle is secure.6. RETIGHTEN the bolts of chipper knives and counter knives.7. GREASE Lubrication Points as per the User Manual Lubrication Chart using a lithium grease.8. LUBRICATE machine parts as per the User Manual Lubrication Chart and ensure machine has sufficient transmission oil, and gasoline. ※29. CHECK the hydraulic system (tank, pump, motor) for hose wear and cracks, oil leaks, and loose connections (nuts and bolts etc) and that the tank contains enough oil. ※310. CLEAN engine and rubber crawlers.11. CHECK for incorrect tension, cracks and / or wear of belts and chains.12. RECORD the hours indicated on the Hour Meter.13. CHECK that the tension of the wires engaging the parking brake, side clutch, transport clutch and rotor clutch is appropriate and effective.14. CHECK the battery fluid is full and the battery terminals are clean.15. ENSURE the screen is installed before commencing chipping operations. Chipping hard materials without the screen may cause damage to the blower fins.16. If operating in freezing conditions, SPRAY Teflon fluid on side clutch wires to prevent freezing. <p>Notes:</p> <p>※1 Engine oil must be replaced in first 5 hours and then every 50 hours.</p> <p>※2 Shell Spirax S3 T 15W-40; Gasoline unleaded</p> <p>※3 Hydraulic oil - ISO VG46 or equivalent viscosity.</p> <p>Refer to the User Manual List of Consumable Parts and the Regular Service and Maintenance sections for parts details and instructions for regular service and maintenance.</p>

HOW TO OPERATE MACHINE



DANGER

Read the Pre-Operating Safety Checklist and Pre-Operating Machine Checklist before starting the engine.

Whenever the terms "Right", "Left", "Forward" and "Reverse" are used in this manual, they indicate the directions from the operator facing forward looking into the hopper.

STARTING THE ENGINE

1. Make sure that the Brake Handle is DOWN.

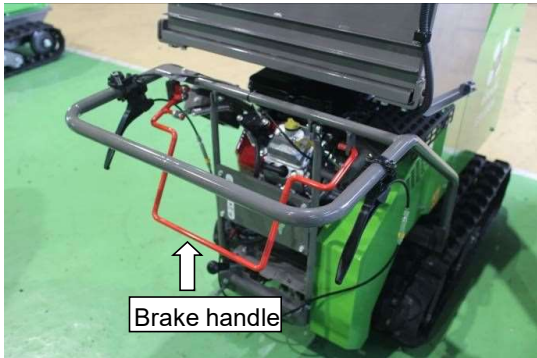

2. Move the shift lever to neutral "N".

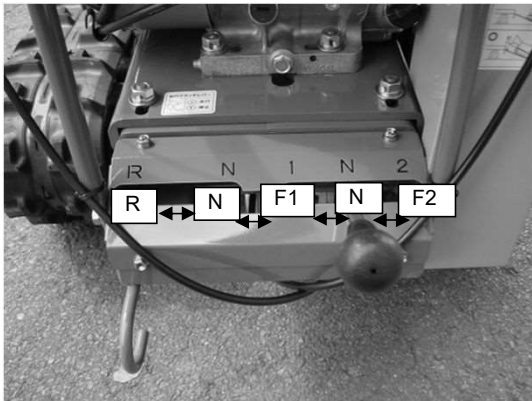

3. Rotor clutch lever should be in the "OFF" position.

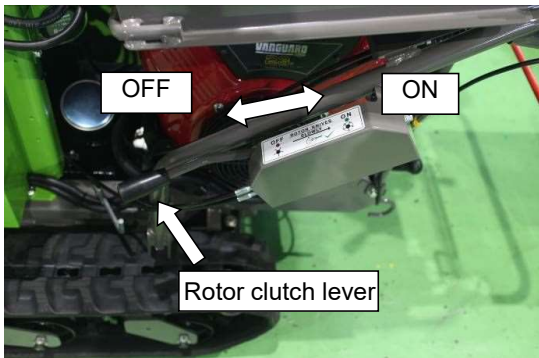

4. Turn the fuel cock to "OPEN"

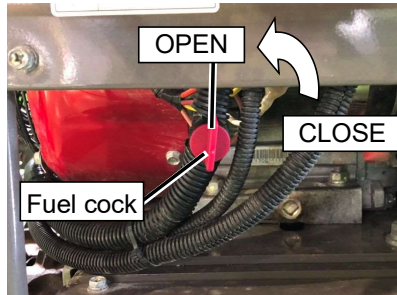

5. Move the choke lever to CLOSED before starting the engine. Move back to OPEN the moment you turn the key and start the engine.

(Do not hold the key in START for more than 5 seconds.)

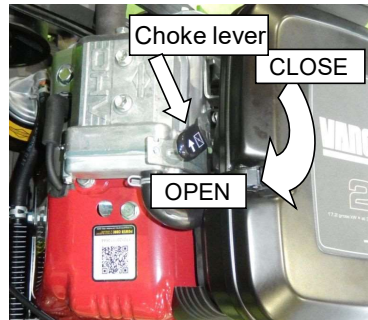

CAUTION

When the engine doesn't start, try again 1 minutes later.

6. After the engine starts, allow the engine to warm up for 1-2 minutes with low running speed.

CAUTION

If engine key start is turned 3 or more time in a row engine may flood. Move the choke lever to OPEN and throttle lever to full throttle and try again. Too much fuel in the engine cylinder makes it difficult to start the engine.

HOW TO OPERATE MACHINE

HOW TO DRIVE THE MACHINE

CAUTION 1

Prevent materials getting caught between the crawler wheels and rubber crawlers or damage to the transmission may occur.

1. Ensure brake handle is down.
2. Move the throttle lever to low.
3. Place shift lever in the gear of choice.

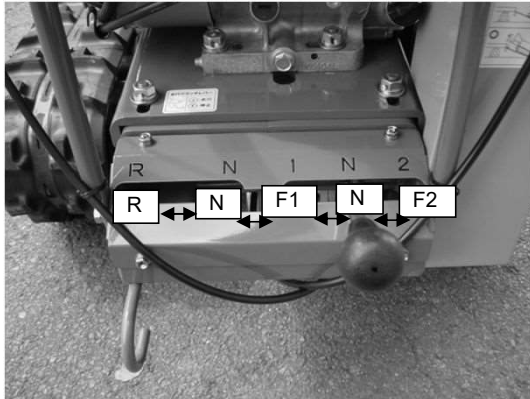

4. Move the brake handle lever up and adjust throttle.

CAUTION 2

When the brake handle is lowered, the parking brake is engaged automatically. When the brake handle is raised up, the parking brake is disengaged automatically.

CAUTION 3

Because the brake handle is connected with the parking brake, it is sometimes hard to move the shift lever.

CAUTION 4

When moving the shift lever between gears put the brake handle down.

HOW TO STOP THE MACHINE

1. Turn the throttle lever to the LOW position and slow down the machine speed.
2. At a flat area move the brake handle down.
3. Move the shift gear to neutral "N".
4. Turn the engine off and remove the key.



5. Close the fuel cock.

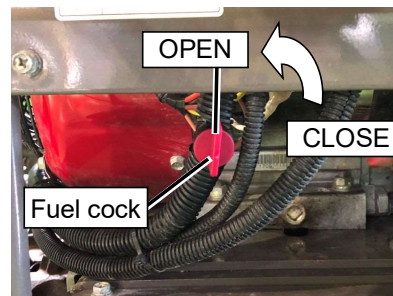

HOW TO OPERATE MACHINE

ADJUSTING THE THROTTLE

CAUTION 1

When adjusting the throttle, ensure that the surroundings are clear of obstacles and people who may be in the path of the machine.

CAUTION 2

Be careful of adjusting the throttle too quickly as any slopes or obstacles may unbalance the machine or cause it to tip over which may cause serious injury.

1. Locate the throttle lever close to the left turning control handle.
2. Adjust throttle slowly to control the speed of the machine.

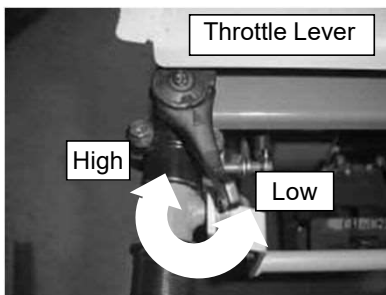

TURNING THE MACHINE

1. To turn the machine to the left hand side, grip the left turning control lever under the handle.
2. To turn the machine to the right hand side, grip the right turning control lever under the right handle.

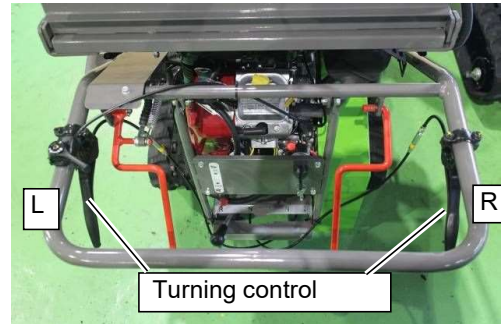

CAUTION 1

When both levers are applied at the same time, the machine stops.

HOW TO OPERATE MACHINE

LOADING, UNLOADING & SLOPES

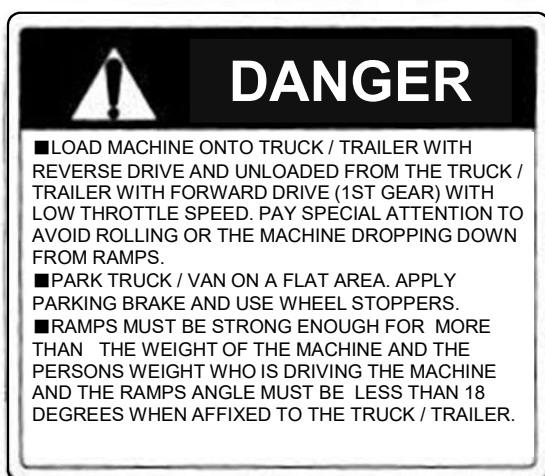

1. How to load and unload on/from the truck / trailer.
 - a) Loading and unloading must be carried out at a flat and safe area.
 - b) Stop truck engine, apply parking brake. Wheel stoppers should also be used so that the truck / trailer does not move at all.
 - c) Use the ramps which are strong enough and put it in the correct position so that the rubber crawlers of the machine are positioned in the center of the ramps.
2. Suitable ramps for loading and unloading
 - a) Strength, width, length and grip must be sufficient for loading the machine on the truck / trailer.
 - b) Ramps must have affixing devices such as hooks to affix to the truck / trailer.
 - c) The ramps length should be at least 3.5 times longer than the height between the ground and the truck / trailer platform.
 - d) The ramp sloping angle when attached to the truck trailer / should be no more than 18 degrees.
 - e) Ramp width should be wide enough to meet the width of rubber crawler.
 - f) The ramps must be strong enough to accept the machine and operator weight.
 - g) Ramps must have enough gripping power so that the machine does not slip on the ramps.

WARNING 1

If using a truck / trailer with a roof, ensure that the operator does not breath exhaust gas when starting the engine to load / unload machine from the truck / trailer. Ensure adequate ventilation.

WARNING 2

Loading and unloading should be carried out on a flat area. Unexpected accident may happen.

WARNING 3

Make sure that the ramps hooks are fixed firmly at the truck / trailer platform and there should not be any significant gap and / or step.

WARNING 4

When loading and unloading, never try to change the machine direction or to shift the driving speed on the ramps.

WARNING 5

When the machine passes over the border between the truck / trailer and ramps, the center of gravity of the machine changes suddenly. The operator should know this fact so as to avoid the machine tipping or falling off the ramps.

WARNING 6

During transportation in a truck / trailer, the machine brake handle must be down and fuel cock in the CLOSED position.

The machine should be fixed firmly inside the truck / trailer to prevent the machine moving and wheel stoppers should be put against the wheel crawlers.

Serious accident may happen if the machine is not fixed firmly inside the truck / trailer.

WARNING 7

When loading and unloading, ensure the rubber crawlers are positioned in the center of the ramps.

WARNING 8

The machine must be loaded to truck / trailer in backward drive and unloaded in forward drive with the first gear.

WARNING 9

Never drive up / down a slope slanting more than 18 ° or drive sideways on a slope slanting more than 5° and always stand up slope from the machine when driving.

WARNING 10

Ensure machine does not roll or fall off ramps.

HOW TO OPERATE MACHINE

HOISTING THE MACHINE

CAUTION 1

When hoisting the machine maintain the correct balance, and ensure your hoisting apparatus can maintain the weight of the machine.

CAUTION 2

The hoisting point is designed only to lift the weight of the machine. Ensure the hoisting point is not damaged before use.

1. Use the hoisting point on the machine as indicated in the picture below.

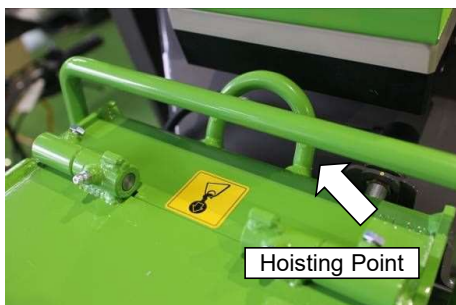

2. Remove the hoist setting pin from its location as indicated in the picture below.



3. Insert the hoist setting pin in the hole as indicated in the picture below.



HOW TO OPERATE MACHINE

CHIPPING OPERATIONS

DANGER

1. Read the **Pre-Operating Safety Checklist** and **Pre-Operating Machine Checklist** before starting the chipping operation.
2. Make sure that no metals, steels, stones, sand etc. are contained in the woods to be chipped / shredded before starting the operation.
3. During chipping operation:
 - a) When the chipping operation is carried out, the brake handle must be down.
 - b) The chipping work must be carried out only when the engine is running at full throttle.
 - c) Pay attention to machine noise when the machine is operated in a place where people are living.
4. Pay attention to the muffler and surrounds because it becomes very hot during the operation and after operation.

POSITION THE SHOOTER

CAUTION 1
Dust arising from dispatched wood chips that gathers around the engine can cause engine troubles. Therefore, consider wind direction and position the shooter direction accordingly.

CAUTION 2
In the case whereby the shooter becomes clogged, place the rotor clutch lever to OFF, turn off the engine, and wait for moving parts to stop before attempting to unblock.

DANGER
Wood chips are dispatched from the shooter at high speeds. Be careful not to position the shooter in a dangerous position which may cause injury or harm to people.

1. Before commencing chipping operations use the shooter handle to turn the shooter to the direction desired.
2. Secure the shooter tightly in position.

POSITION THE LOW DISPATCH UNIT

DANGER 1
When using the low dispatch unit the yellow safety guard must be fixed in position.

DANGER 2
When unlogging ensure the engine is off, the key is removed, and all moving parts have stopped before unlogging.

CAUTION 1
The low dispatch unit can not be used simultaneously with the shooter.

CAUTION 2
The low dispatch unit can become clogged. Check regularly and unlog if necessary.

1. After the engine is switched off and all moving parts have stopped, remove the 4 bolts affixing the safety guard to the machine.

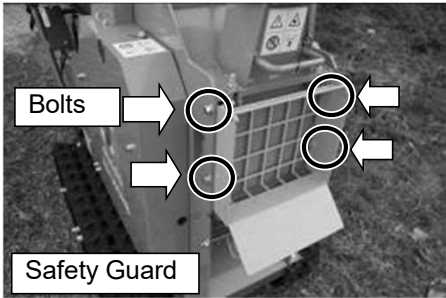

2. Remove the safety bolt and pull out the 2 pins securing the blower cover.

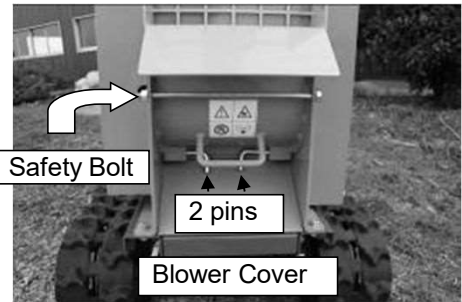

3. Open the blower cover.



HOW TO OPERATE MACHINE

POSITION THE LOW DISPATCH UNIT (cont.)

4. Position the safety guard in position and secure with bolts.

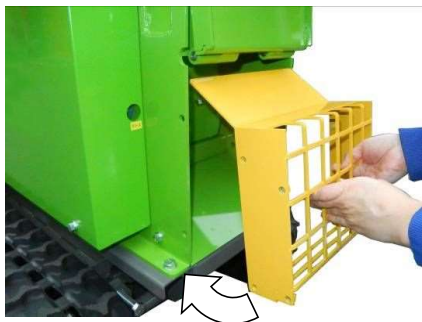

5. You are now ready to use the low dispatch unit.



ROTOR CLUTCH

CAUTION 1

If blower gets clogged with the rotor clutch lever still in the ON position the rotor and blower belts may be damaged. Check for clogging regularly.

CAUTION 2

The engine will stop suddenly or a belt will be damaged if the rotor clutch lever is shifted to the ON position suddenly. Therefore, always move the rotor clutch lever SLOWLY from OFF to ON slowly.

1. Make sure that the rotor clutch lever is OFF completely before engine starts. Move the engine throttle lever to the high position, running the engine in full throttle.
2. Slowly move the rotor clutch lever from the OFF position to the ON position checking that there is no extra-ordinary vibrations. Hold the rotor clutch lever in the middle position between OFF and ON for 5 seconds, before fully moving it to the ON position.



3. The blower and the rotor will begin turning at the same time. The sound from the blower unit should indicate that the blower is rotating.
4. The machine should be operated for chipping only at the maximum engine power.
5. To stop the rotor, stop the feed roller, turn the throttle lever to low and turn the rotor clutch lever OFF.

HOW TO OPERATE MACHINE

FEED ROLLER OPERATION

DANGER

1. Do not place hands or feet near the feed roller at any time.
2. Do not attempt to remove materials stuck in the feed roller directly with your hands.
3. Ensure that the machine and engine parts have stopped when removing stuck materials from the feed roller.
4. Do not place hands near the feed box while the feed roller is operating as sudden movements may cause injury.

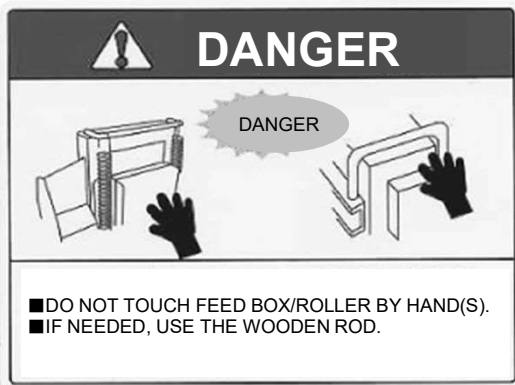

5. Do not place hands near the feed roller while feeding material into the hopper. Be very careful not to be caught in the feed roller.
6. Do not place your hands into or near the shooter or low dispatch unit while the engine is running.

FEED SWITCH

1. Turning the feed switch to the right "IN" position makes the feed roller rotate pulling material into the rotor.
2. Turning the feed switch to the left "OUT" position makes the feed roller rotate pulling material out of the rotor and exit via the hopper.
3. Turning the feed switch to the centre "STOP" position makes the feed roller stop rotating.

NOTE

The no stress electronic automatic feeding system will stop the feed roller momentarily when the engine is heavily loaded and start the feed roller again once the engine is moving freely.

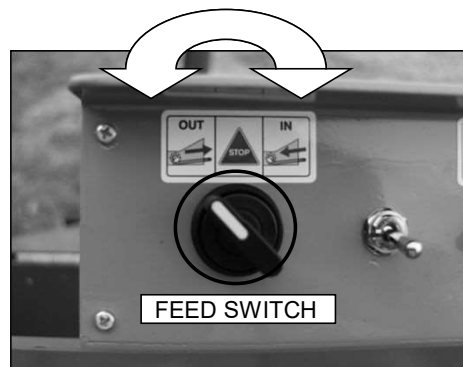

FEED MODE SWITCH

The feed mode switch allows the user to match and optimize the feeding settings to the material being chipped.

1. Left position: Standard / Fast Mode
Move the switch to "STANDARD / FAST MODE" for the fastest chipping of branches no larger than 13cm wide.



2. Right position: Big Log Mode
Move the switch to "BIG LOG MODE" to if branches are 14cm or greater wide. Feed speed may reduce.

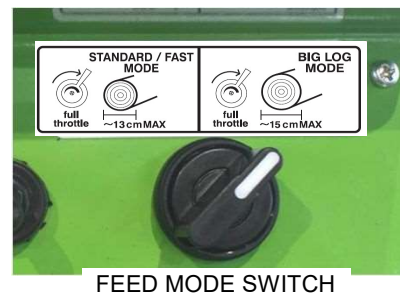

HOW TO OPERATE MACHINE

FEED ROLLER SAFETY BAR

The feed roller safety bar allows the user to stop the feed roller in an emergency and if necessary without using their hands (as shown below).



CAUTION 1

Before machine use, check that the feed roller safety bar when engaged halts the movement of the feed rollers. If when engaged (pushed in) the feed rollers do not stop, contact your dealer to repair the device immediately.

ENGAGE FEED ROLLER SAFETY BAR

1. After starting the engine, putting the engine to full throttle and putting the rotor clutch to ON, check that the feed switch is in the right position "IN".

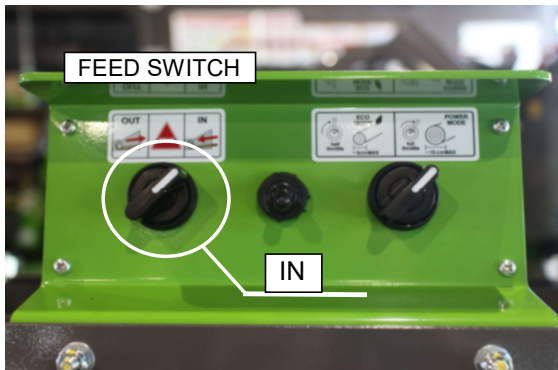

2. Push the feed roller safety bar in (toward the rotor) and check that the feed roller has stopped.



DISENGAGE FEED ROLLER SAFETY BAR

1. Pull the safety bar release lever to release the feed roller safety bar.

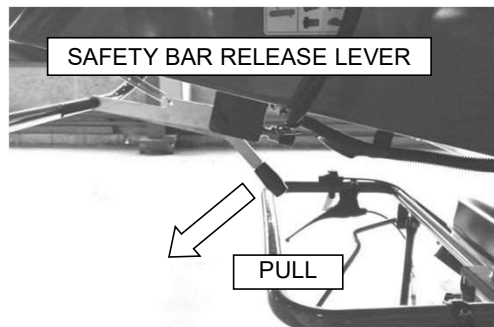

2. Return the feed roller safety bar to its original position, pulled in the direction toward the operator. At this moment, the feed roller must not start yet.

3. Switch the safety bar release switch and check that the feed roller starts again.



CAUTION 1

Do not remove, jam, disable, bypass, override or otherwise impede the effectiveness of the feed roller safety bar.

CAUTION 2

Do not position the hopper in higher or lower positions such that the effectiveness of the safety bar is compromised.

HOW TO OPERATE MACHINE

FLOW CONTROLLER

※Flow controller is for **ES151GHB** only and an option for **ES151GH**.

Adjust the feeding speed of the feed roller manually using the flow controller allows users to process materials slowly and produce small / fine chips or process materials faster and produce larger chips.

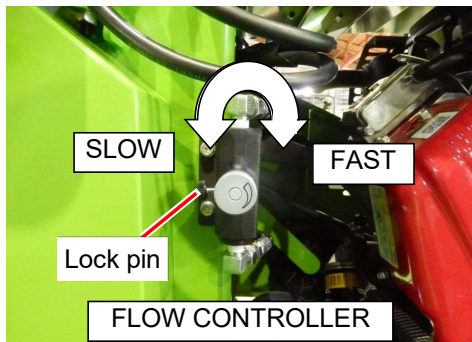

CAUTION 1

Check the size of chips that are discharged and adjust the flow controller appropriately. If input materials are returning via the hopper the rotor may be overloaded. To prevent the engine cutting out reduce the speed of the flow controller.

CAUTION 2

When using the standard screen with the feed mode switch in the normal position ensure the flow controller is turned to full speed.

CAUTION 3

If the flow controller is adjusted to be running at too slow a speed the feed roller may stop. In this case increase the flow controller speed.

CAUTION 4

If the flow controller is set to extremely slow speeds the oil temperature will increase. As the temperature increases so the viscosity will drop. In this case the feed roller may stop moving all together.

1. Adjust the flow controller to suit the size of the chips you wish to produce and consider the size, hardness of the input materials and also the screen size being used. Very small screen sizes should be used with a slow speed of the flow controller.
2. Turn the flow controller clockwise for faster processing and anti-clockwise for slower processing.

NOTE

5mm screen: From full speed position turn a full revolution 4 times in an anti-clockwise direction
8mm screen: From full speed position turn a full revolution 3 times in an anti-clockwise direction

FEED ROLLER CLOGGING PREVENTION

To prevent clogging during chipping operations:

1. Begin chipping operations only when the engine is running at full throttle.
2. The rotor clutch lever must be all the way in the ON position and not half way.
3. Check the belt tension on the rotor and ensure the power is transmitted to the rotor sufficiently.
4. When leaves and wood etc are wet they are not chipped efficiently and are more likely to clog the machine.

HOW TO OPERATE MACHINE

CHANGING SCREENS

※Extra screen is only attached to **ES151GHB** and an option for **ES151GH**.

WARNING 1

When changing screens always ensure the engine is off and the moving parts have stopped.

WARNING 2

Wear gloves and ensure not to cut your hands on the sharp knives in the rotor cover.

1. Remove bolts and take out the shooter.
2. Loosen the bolts of the rotor cover.
3. Open the rotor cover.

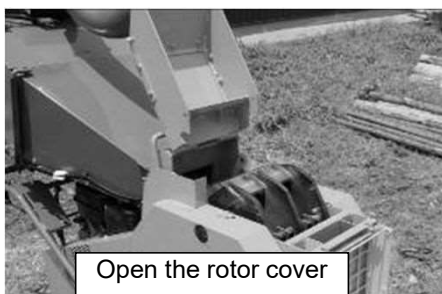

4. Take out the screen in the machine.

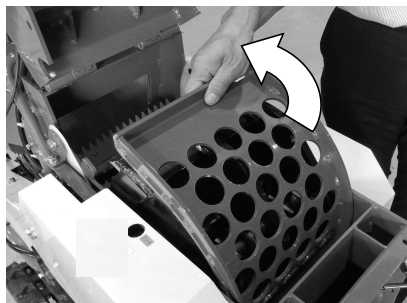

5. Grab the screen you wish to insert in the machine and check which end should go into the machine first. (The end with the shorter gap between the (holes and the screen edge should go in first).

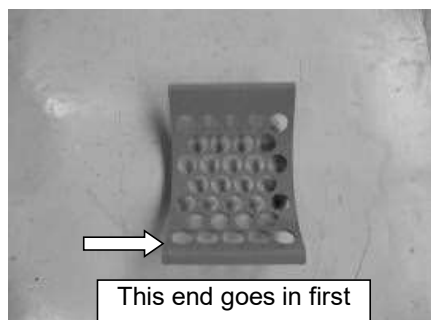

6. Insert the screen into the machine. Check that it fits securely and then close the rotor cover and affix the bolts firmly.
7. Attach the shooter back and fix the bolts firmly.

START CHIPPING WORK OPERATIONS

After reading and understanding all the instructions in this "How to Operate Machine" section you may commence chipping operations.

Note

Maximum diameter of infeed materials allowed is 15 cm for soft wood.

HOW TO OPERATE MACHINE

FEED ROLLER CLOGGING RELEASE

DANGER

Ensure the engine and chipping components have come to a complete stop before attempting to release any clogged material from the machine.

Do not use your hands to remove materials stuck in the feed roller.

Use a wooden broom or other wooden instrument to remove stuck materials.

Do not place hands near the feed roller / feed box.

Be careful of the feed roller and feed box when clogged material is released from under the feed roller. When clogged material is released, the feed roller suddenly drops down and would crush a persons hands.

Avoid injury and be very careful of sharp knives when unclogging the rotor and use gloves.

1. Turn the feed switch to the OUT position and clogged material will be released via the hopper.



IF ROTOR OR FEED ROLLER WILL NOT TURN

1. Move the rotor clutch lever to OFF and then turn the engine off and remove the key.
2. Wait for all engine parts and chipping components to stop moving.
3. Move the rotor clutch lever to the ON position which will stabilize the rotor.
4. Open the rotor cover.
5. Unclog the rotor of clogged materials.
6. Replace the rotor clutch lever to the OFF position.

7. Lightly and carefully rotate the rotor manually to check it is revolving freely without obstruction.
8. Close and secure the rotor cover.
9. Move the feed switch to neutral "N".
10. Turn on the engine, maximize throttle and put the rotor clutch lever to ON.
11. Turn the feed switch to the OUT position and any remaining clogged material will be released via the hopper.

ENGINE WILL NOT START

1. Move the rotor clutch lever to OFF and then remove the key.
2. Put the feed switch to the OUT position.
3. Wait for all engine parts and chipping components to stop moving.
4. Move the rotor clutch lever to the ON position which will stabilize the rotor.
5. Open the rotor cover.
6. Unclog the rotor of clogged materials.
7. Replace the rotor clutch lever to the OFF position.
8. Insert the thick end of the Rotor Lock Pin into the hole (per picture below) and into the pulley socket and rotate quickly in a clockwise direction until the clogged material is released out of the hopper.

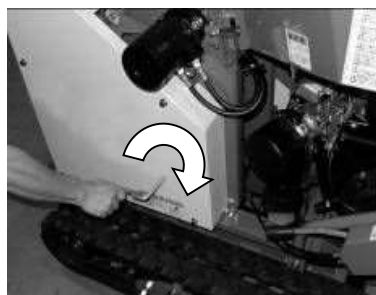

Note

If the control box fuse 1A is blown, the feed rollers no stress system will stop working which may cause the engine to overload and to cut out.

REGULAR MAINTENANCE

DANGER

1. Before any inspection or maintenance:
 - a) Switch Rotor Clutch Lever - OFF
 - b) Put Brake Handle - DOWN
 - c) Switch Feed Switch - STOP
 - d) **Switch Engine OFF** and remove key
2. ENSURE that machine and engine parts are not moving and / or hot.
3. WEAR gloves when handling knives. Be careful as the knives are very sharp.
4. REPLACE all covers, guards and housing parts after inspection.

KNIFE BASICS

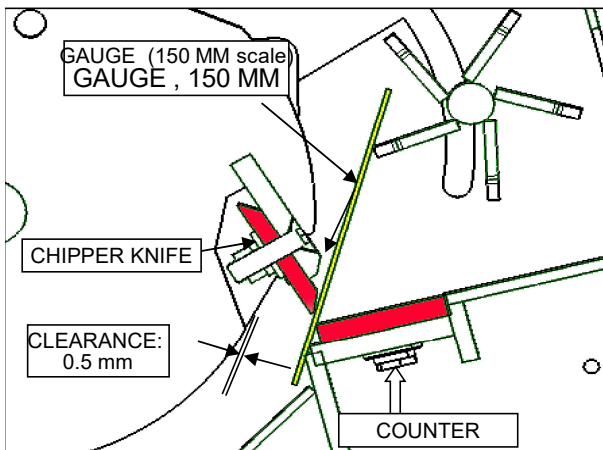

CHIPPER KNIFE - LIFE AND SHARPENING

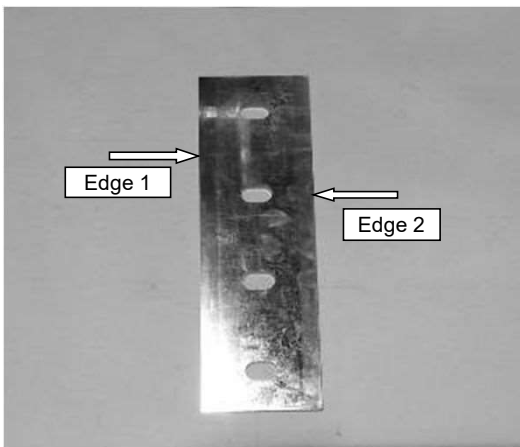

Cutting Edges	Use
Edge 1	25 hrs

Alternate edge (Turn)

Edge 2	25 hrs
--------	--------

Sharpen both edges and use again

Note: Sharpen approx. 5 times (300 hrs knife life). Refer "**Remove & Affix Knives**" to alternate edge.

COUNTER KNIFE - LIFE AND SHARPENING

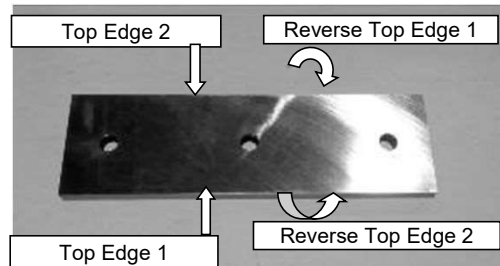

Cutting Edges	Use
Top Edge 1	50 hrs

Alternate edge (Turn)

Top Edge 2	50 hrs
------------	--------

Alternate edge (Flip)

Reverse Top Edge 1	50 hrs
--------------------	--------

Alternate edge (Turn)

Reverse Top Edge 2	50 hrs
--------------------	--------

Sharpen all four edges and use again

Note: Can sharpen approx. 3 times = 800 hrs knife life. Refer to "**Remove & Affix Knives**" to alternate edges.

REGULAR MAINTENANCE

If chipper or counter knives becomes dull, it can cause clogging, extra noise, and rotor overloading. Check knives regularly for damage, cracks or dullness. or chipping efficiency is reduced. Always clear dust, dirt or chips before affixing knife bolts or they may become loose easily.

REMOVE & AFFIX KNIVES - CHIPPER KNIVES

WARNING

ALWAYS turn engine OFF before opening covers. ALWAYS put rotor clutch lever to OFF position and wait till moving parts stop before starting maintenance.

1. Remove bolts and take out the shooter.
2. Remove bolts and open the rotor cover.
3. Take the rotor lock pin and insert in rotor so that the rotor does not move (see pictures below).

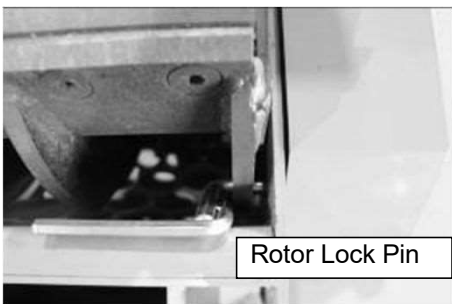
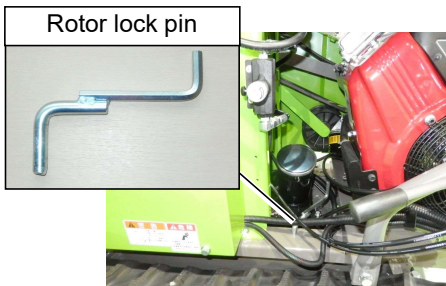

4. With the rotor cover open, insert a hex key into the 4 socket bolts affixing the chipper knife to the rotor and loosen the nuts on the other side.
5. Remove chipper knife and alternate edges by turning knife or replace knife. Tightly secure socket bolts (110 N.m torque wrench).
6. After mounting the chipper knives, the clearance between chipper knives and counter knife must be adjusted according to "**Knife Adjustment**".
7. Remove the rotor lock pin and close the rotor cover and affix the rotor cover fixing bolts tightly.
8. Attach the shooter back and fix the bolts firmly.

REMOVE & AFFIX KNIVES - COUNTER KNIFE

If the counter knife becomes dull, chipping efficiency is reduced.

1. Loosen bolt and open rotor cover and hopper.

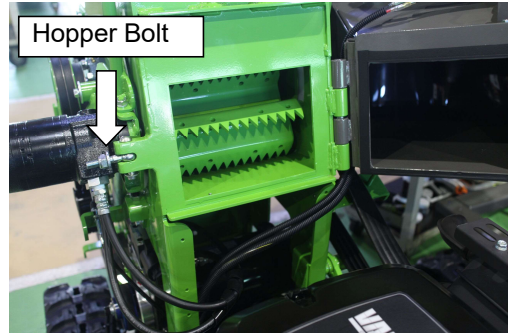

2. Loosen and remove the 3 x M12 bolts fixing the counter knife to its bed.

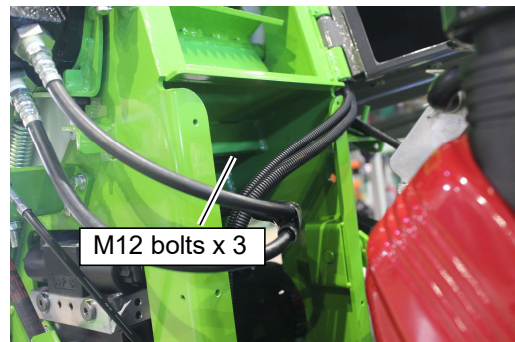

3. Remove counter knife and alternate edges or replace knife with a new one. Tightly secure the 3 fixing bolts.
4. After mounting the counter knife, the clearance between chipper knives and counter knife must be adjusted according to "**Knife Adjustment**".
5. Remove the rotor lock pin and close the rotor cover and affix the rotor cover fixing bolts tightly.

IMPORTANT

ALWAYS perform knife adjustment after moving knives. Refer "**Knife Adjustment**" in this manual.

- 1) Replace spring washers after moving knives.
- 2) When replacing knives, also replace bolts, nuts, spring washers and plain washers.

REGULAR MAINTENANCE

KNIFE ADJUSTMENT (IMPORTANT)

After removing or affixing either chipper or counter knives **clearance between the chipper knife and the counter knife must be adjusted correctly.**

WARNING

ALWAYS turn engine OFF before opening covers.
ALWAYS put rotor clutch lever to OFF position and wait till moving parts stop before starting maintenance.

Refer to "**Remove & Affix Knives**" section of this manual for instructions on loosening knife fixing bolts.

1. Loosen chipper or counter knife fixing bolts per instructions at "**Remove & Affix Knives**".
2. Remove two chipper knives remove the chips on the knife base.

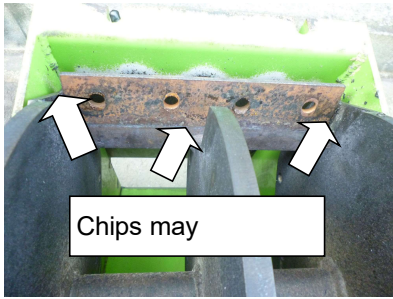

3. Remove counter knife and alternate edges or replace knife with a new one. Lightly fasten the 3 fixing bolts.

CAUTION

- (1) Replace spring washers after moving knives.
- (2) When replacing knives, also replace bolts, nuts, spring washers and plain washers.

4. Remove the rotor lock pin and rotate the rotor slowly by hand until the chipper knife base meets the counter knife (Refer to the second picture below.).

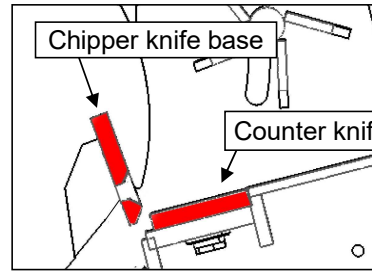
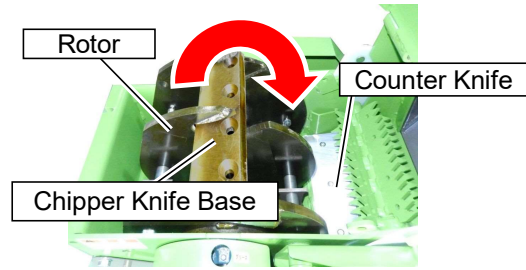

5. Put the two of 150 mm scale together and adjust the clearance between the counter knife and chipper knife base (1.0 mm) as in the picture below. Move the counter knife to adjust the clearance.

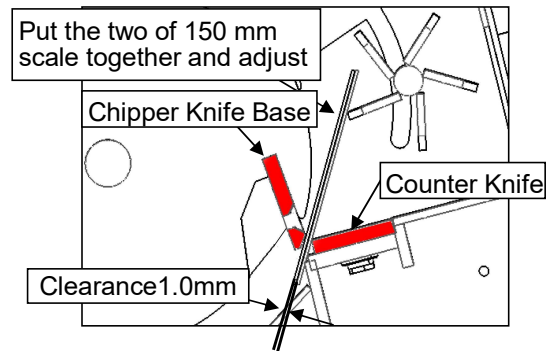

6. When adjustment is done, tighten the three fixing bolts tightly with 110Nm torque.

CAUTION

Make sure not to forget to secure the knife fixing bolts firmly.
If the bolts remove during operation, it can cause a big damage not only to the machine but also to the operator.

7. After the adjustment of the counter knife, fix the rotor with the rotor lock pin and affix and adjust chipper knives.

REGULAR MAINTENANCE

8. Set the rotor lock pin and turn, flip or change chipper knives. Lightly fasten the 4 fixing bolts on both two knives.

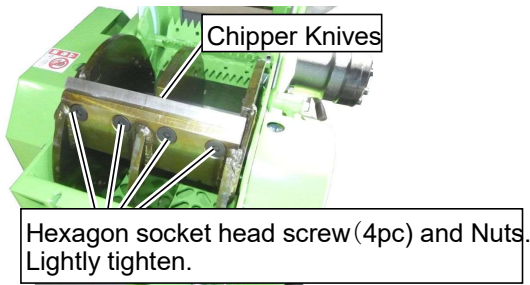

CAUTION

- (1) Replace spring washers after moving knives.
- (2) When replacing knives, also replace bolts, nuts, spring washers and plain washers.
- (3) When replacing knives, replace both two knives but not just one of them.

9. Adjust the clearance moving the chipper knife. Use one 150 mm scale and adjust the clearance between the counter knife and chipper knife. Remove the rotor lock pin and rotate the rotor slowly by hand to check if the chipper knives don't hit the counter knife and if there is a gap approximately 0.5 mm.

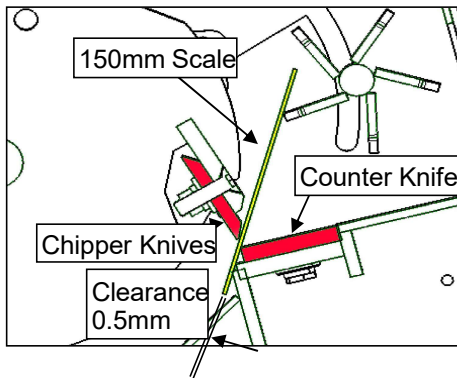

10. When adjustmet is done, tighten the 4 fixing bolts tightly with 110Nm torque.

CAUTION

Make sure not to forget to secure the knife fixing bolts firmly. If the bolts remove during operation, it can cause a big damage not only to the machien but also to the operator.

11. Rotate the rotor slowly by hand again to make sure that the chipper knives don't hit the counter knife and there is a gap approximately 0.5 mm.



12. After turn, flip and change knives, put the rotor lock pin, the covers and the hopper back to their original position and secure them firmly with the bolts.

REGULAR MAINTENANCE

REMOVE, TURN & AFFIX SHREDDER KNIVES

When the shredder knives become blunt, turn them so that the sharp corner of the knife is hitting the infeed materials. When all 4 corners of the shredder knives become blunt, replace them.

1. Remove bolts and take out the shooter.
2. Loosen the rotor cover bolts and open the rotor cover.

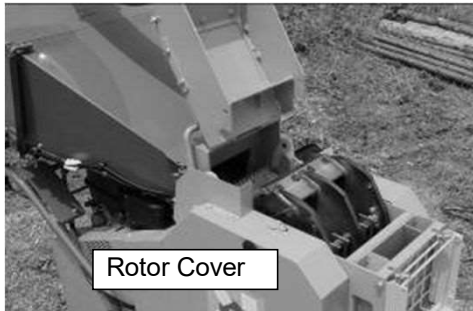

3. Take the rotor lock pin and insert in rotor so that the rotor does not move.
4. Affix the shredder knife shaft brace to the side of the rotor cover.

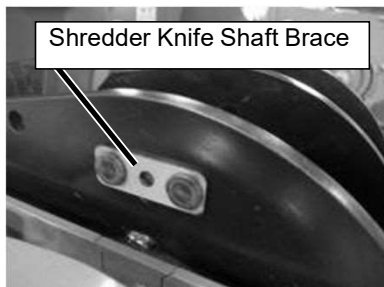

5. From the other side of the rotor to where you affixed the shredder knife shaft brace, insert the shredder knife shaft and put 2 shredder knives and 3 spacers on the shredder knife shaft as seen below.

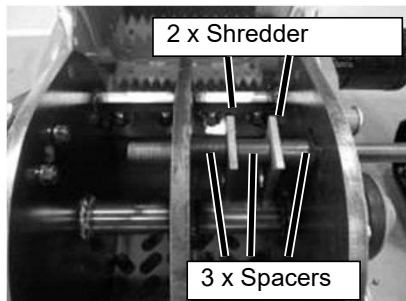

6. As described above at 4, put 2 shredder knives and 3 spacers on the left side of the shredder knife shaft.

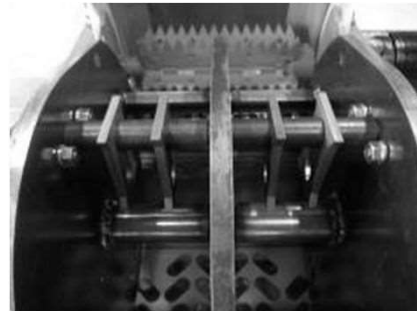

7. Affix a shredder knife shaft brace to the other side of the rotor cover and secure tightly the shredder knife shaft.
8. Rotate the rotor 180° and complete the steps above from 3 ~ 6 for the other side of the rotor.
9. Remove the rotor lock pin and close the rotor cover and affix the rotor cover fixing bolts tightly.
10. Attach the shooter back and fix the bolts firmly.

REGULAR MAINTENANCE

RE-FUELING

DANGER

1. NEVER remove safety covers or refuel with engine on, parts still moving or machine still hot.
2. Never smoke while handling fuel or when servicing engine. Do not handle fuel or service engine near naked flames or uncovered electrical lighting.
3. Carry out any test drives on a level ground in an open and safe place where there is no obstruction.
4. Replace all covers, guards and housing parts after inspection and service.

* According to the operating situation, parts exchanging interval could be shortened. Recommend you to carry out the inspection and maintenance often.

ADDING GASOLINE

1. Open the fuel cap and fill tank with gasoline.

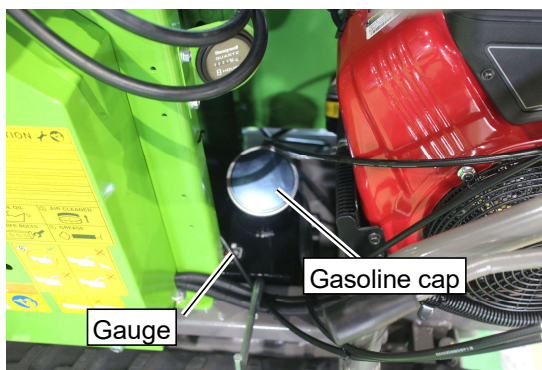

2. Replace the fuel cap.

DRAINING GASOLINE

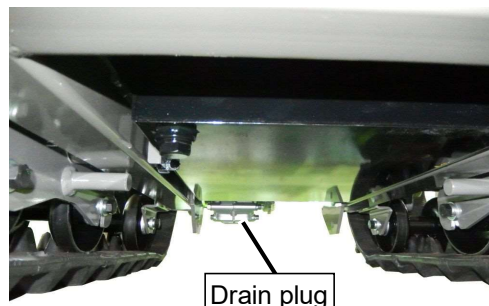
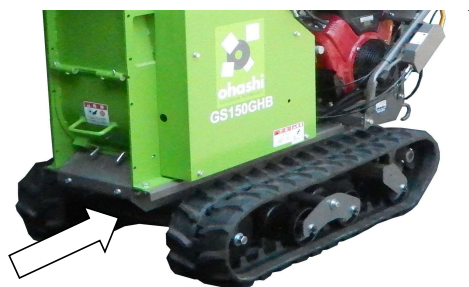

CAUTION 1

If there is water or any dirt in the fuel, it causes not only engine out put insufficiency but also a damage to fuel system.

Open the drain plug and remove the water and the dirt from the fuel tank. Drain at least 1 or 2 litres of gasoline to make sure that the water and the dirt are removed.

CAUTION 2

Make sure that there is enough fuel in the tank when the machine goes on a slope. The tank need to be filled more than half of the tank quantity.

If a sacking hole in the tank in exposed from the fuel when driving on a slope.

CAUTION 3

Fuel can become stale when stored over 30 days. Stale fuel causes acid gum deposits to form in the fuel system or on essential carburetor parts. To keep fuel fresh, use a fuel stabilizer or drain fuel from the tank. Refer to the "Long term storage".

REGULAR MAINTENANCE

HOUR METER

When performing regular maintenance of the machine take note of the hour meter so that inspections are performed regularly.



OIL CHANGE

Refer to the diagrams below for guidance.

	Oil type	Capacity	Oil Change Interval
Engine Crank Case	SF, SG, SH, SJ or higher	1 l	After first 5 hrs. then every 50 hrs.
Transmission	Shell Spirax S3T 15W-40	0.7 l	After first 50 hrs. then every 200 hrs. (of use in transportation)
Hydraulic Tank	ISO VG46 (or equivalent)	3.0 l (with gauge)	Every 300 hrs.

CHANGING ENGINE OIL

1. Deteriorated engine oil decreases the machine's operating ability and can cause engine failure. Periodically change engine oil.
2. Drain the oil while it is warm, because warm oil drains better. However, to avoid burn injury do not drain while the oil is hot.
3. Before operating the machine ensure that the oil is full.

CAUTION

1. Use quality oil of SF grade or better. Do not start machine without sufficient oil in the engine.
2. When using multi-grade oil, remember that oil consumption rate increases as the ambient temperature increases.
3. Always place machine on flat ground before checking oil levels.

REGULAR MAINTENANCE

HYDRAULIC TANK OIL

1. Replenish the hydraulic tank with ISOVG 46 oil or an equivalent viscosity.
2. When using the gauge to measure the oil quantity screw the gauge into the opening of the hydraulic tank and then unscrew and pull out. The oil should have reached approx. the mid way point of the gauge.
3. Hydraulic oil lasts a long time however if it runs out operations will be adversely affected therefore check the oil level every 100 hours.

CHANGING HYDRAULIC OIL

CAUTION

Hydraulic oil can be extremely hot after use. Please wait for the oil and machine to cool down after use before attempting to replace or inspect it.

1. Remove the tank drain plug and drain all the oil and replace.

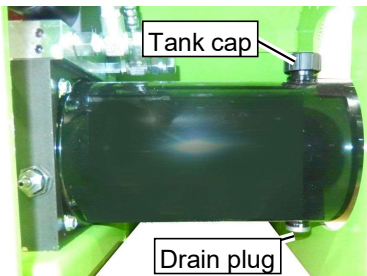
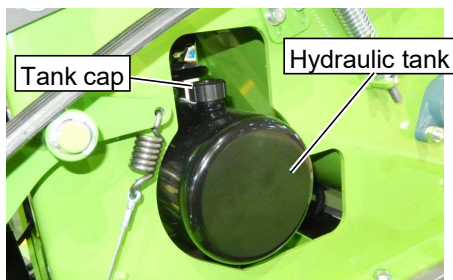

2. Use the most suitable hydraulic fluid viscosity equivalent to ISOVG 46. Shell Tellus S2 M 46 is recommended.
3. Check the oil volume with gauge. Add oil if the volume is not enough.

CAUTION 1

Be very careful not to allow dust, material fiber or any thing other than oil into the tank.

CAUTION 2

Do not wash the hydraulic tank directly with water.

CAUTION 3

If the air temperature is less than 0°C then run the machine lightly for 5 minutes before draining the oil.

※Regarding hydraulic oil change interval and quantity, refer to "OIL CHANGE" on page 33.

HYDRAULIC HOSE

Before using the machine ensure all the hoses, pipes and attachments acting as a medium for the hydraulic oil are in good condition and do not have any cracks or splits or severe wear.

Change hydraulic hoses every 2 years regardless of the frequency of use.

DANGER

1. Do not check the hydraulic oil hoses, pipes and fittings with your hands.
2. Hydraulic oil at high pressures will rip through flesh and cause severe injury. Be very careful.
3. Check that the hydraulic hoses and pipes do not rub on other parts of the machine to avoid wear.
4. Any split or damaged hydraulic hoses, pipes or fittings must be replaced before machine use.
5. Secure all hydraulic hose, pipe and fittings tightly before using the machine.
6. If the hydraulic hoses get twisted, use one spanner to secure the fixing and another to turn the hose. After untwisting, tighten hose and fixing very firmly.
7. Hydraulic assembly hoses and other hydraulic fixing parts need torque as per the table below.

Hydraulic Hose

Size	Metal Fitting required Torque
1/4 (6mm)	24 (N.m)
※ ±10% acceptable variance	
※ Do not apply this torque if oil is spilled on hose metal fitting	

CHANGING TRANSMISSION OIL

Refer to the diagrams below for guidance

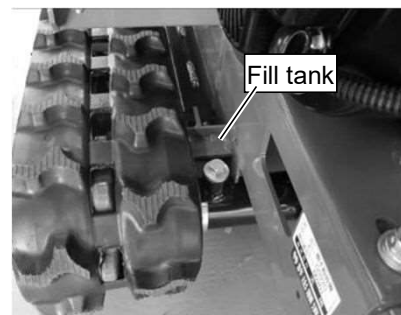

REGULAR MAINTENANCE

TRANSPORT CLUTCH ADJUSTMENT

WARNING

NEVER have safety covers off with engine on.

It is very dangerous if the transport clutch does not work properly.

Stop machine if you feel abnormal movement.

1. Remove the middle and back side covers on the right side of the machine per the picture below.



2. Shift the brake handle up for transport.
3. If the transport clutch wire is loose extend the wire by adjusting the wire adjusting nuts on each side of the metal brace.

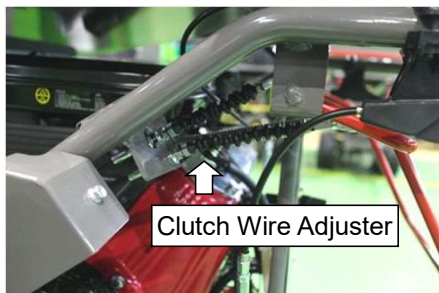

4. Tighten the wire adjusting nuts securely and replace the covers and affix the covers securely.
5. Shift the brake handle down.
Start engine and confirm that the transport clutch is fully disengaged.
6. If the transport clutch does not fully disengage adjust the belt holder bolts.

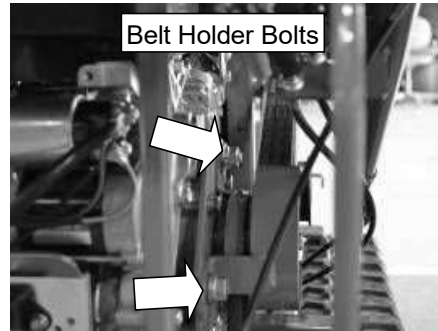

7. When elasticity of transport belt weakens such that it can not be engaged by adjusting transport clutch wire or belt holder replace the transport belt.

TURNING CONTROL LEVER ADJUSTMENT

When the side clutch does not work properly or machine does not turn smoothly, adjust wires for the side clutch.

1. So that the gears in the gear box remain correctly engaged, first without touching the turning control levers, start the engine and move the machine straight forward 2~3 metres.
2. Adjust the side clutch wire adjusting nuts until the turning handle responds as desired when engaged.

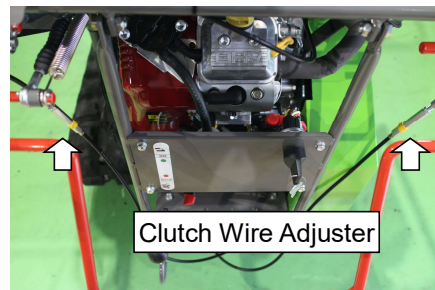

3. Tighten the adjuster nuts securely.

REGULAR MAINTENANCE

PARKING BRAKE

It is very dangerous that the parking brake does not work properly. Immediately stop operating the machine when you feel abnormal conditions and carry out the adjustment mentioned below.

1. Adjustment of the parking brake

- (a) Move the brake handle down thus engaging the parking brake. Check that the brake wire is tensed fully.
- (b) Remove the middle and back side covers on the right side of the machine.

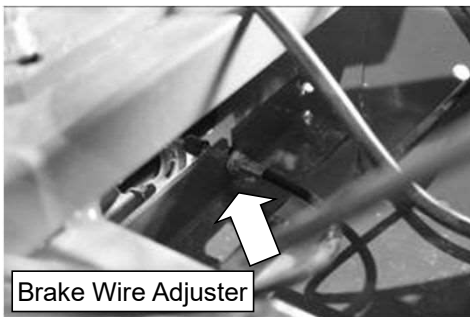

- (c) If the parking brake is not engaging efficiently the wire may be loose. Adjust the wire adjusting nuts on each side of the metal brace to achieve desired response from the parking brake handle.
- (d) Tighten the wire adjusting nuts securely.

2. Checking and replacing parking brake shoe

If even after adjusting the parking brake wire, the parking brake does not respond well, inspect the parking brake pad and replace if necessary. Regularly inspect every 3 months.

- (a) Put the brake handle down and loosen the parking brake wire with the adjuster nuts to the maximum possible.

- (b) Remove M3 screws x 3, seal / gasket without damaging it and then the brake unit.

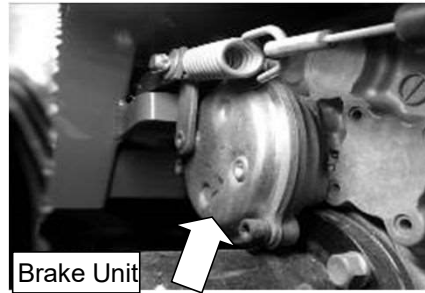

- (c) Remove the snap ring and at the same time the brake drum.
- (d) Replace the brake shoe. Replace the seal / gasket too if necessary. Refit all parts tightly.
- (e) Adjust the parking brake wire to achieve adequate response from the brake handle.
- (f) Replace the parking brake wire if required.
- (g) Tighten the wire adjusting nuts securely.

Note 1: The minimum usable thickness of the brake pad is 1.5mm but it is recommended to be replaced at 2mm. However, always replace brake shoe if the adequate response is not achieved when engaging the brake handle.

Note 2: The parking brake wire can be further adjusted using the wire adjusting nuts located near the right turning control handle.

Note 3: It can be presumed that if the parking brake shoe needs replacing so does the transmission shoe. Inspect and / or contact your dealer.

REGULAR MAINTENANCE

ROTOR CLUTCH

If rotor belt tension weakens, engine power is not transmitted efficiently. Check tension regularly. Belt tension can loosen sooner than usual with new machines. Check before starting operation and adjust when this occurs.

WARNING

NEVER have safety covers off with engine on.

1. Adjust the rotor clutch wire

a) One rotor clutch wire engages the rotor and the other engages the hydraulic motor. Both can be adjusted at two places as below.

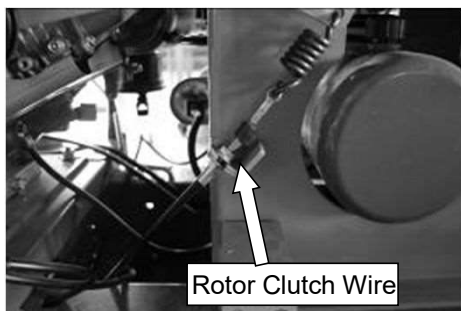
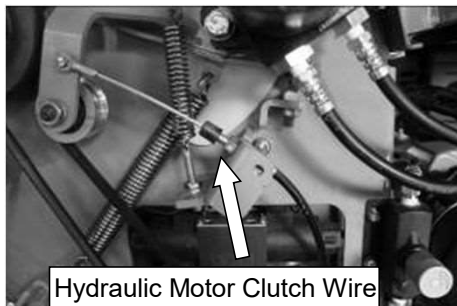
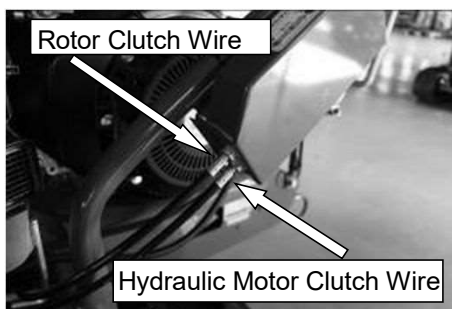

b) If the wire is too slack shorten the wire by adjusting the wire adjuster nut. If the wire is too tight lengthen the wire by adjusting the wire adjuster nut.

c) Ensure that when the rotor clutch lever is OFF the rotor belt is not engaging the rotor.

d) Lastly check the belts tension by putting the rotor to ON (with engine OFF) and push lightly with your finger into the middle of the belt as shown in the picture below. Movement should be 10 ~ 15mm.

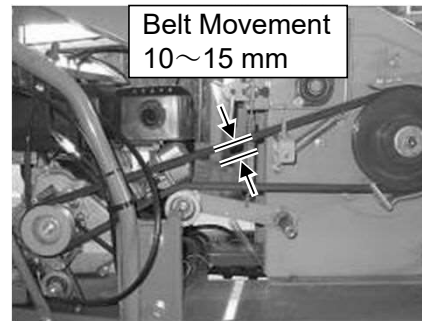

2. Re-tensing of the rotor belt

Where adjusting the rotor clutch wires does not fix the problem proceed as follows:

a) Put the rotor clutch lever to OFF and adjust the rotor clutch wire adjuster nut so that the wire is as loose as possible.

b) Loosen and remove the M10 bolts x 4 attaching the engine to the machine frame.

c) Move the engine in the direction away from the rotor, thus tightening the rotor clutch belt. The gap between the outer edge of the engine pulley and inside edge of the rotor belt should be between 3 ~ 6 mm when pulled lightly.

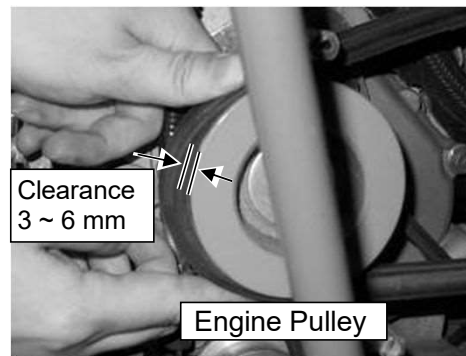

d) Refit and tighten the 4 bolts securing the engine to the machine frame.

e) Adjust the rotor clutch wire if necessary as explained at 1 above.

f) Ensure that when the rotor clutch lever is OFF the rotor belt is not engaging the rotor.

REGULAR MAINTENANCE

3. Replacement of Rotor Belt

In the case where adjustments of the engine position, rotor clutch wire do not result in the correct tension of the rotor belt and / or the rotor belt is damaged or frayed, replace the rotor belt.

- a) Shift the rotor clutch lever to the OFF position.
- b) Remove the front, center and rear covers on the right hand side.
- c) Adjust the rotor clutch wire adjuster nut so that the wire is as loose as possible.
- d) Loosen and remove the M10 bolts x 4 attaching the engine to the machine frame.
- e) Remove the bolts (M10) fixing the rotor belt holder and remove the rotor belt holder and the rotor belt.
- f) Place a new rotor belt in the position around the rotor and engine pulleys and refit the rotor belt holder.
- g) Adjust the belt tension according to the item
 1. **Adjust the rotor clutch wire &**
 2. **Re-tensing of the rotor belt.**

4. Disengagement of the rotor clutch

Reattach safety covers securely and use the transparent window to view the rotor belt.

- a) Shift the rotor clutch lever to the OFF position.
- b) Turn the fuel cock to the OPEN position.
- c) Start the engine and position the throttle lever to the full throttle.
- d) Shift the rotor clutch lever from the OFF to the ON gradually.
- e) Repeat ON to OFF action of clutch lever and check that when ON the rotor belt moves and when OFF the belt stops moving immediately.
- f) If not, stop the engine, close the fuel cock, re-adjust the wire and re-adjust the rotor belt as per item **1** and **2** above.

- g) When all the adjustments are completed, place the covers on the machine and fit tightly.

CAUTION

If letters are printed on the rotor belt, attach the rotor belt to the pulleys so that the written sentence begins at the direction of the engine pulley and ends in the direction of the rotor pulley.

REGULAR MAINTENANCE

RUBBER CRAWLER

Rubber crawler tension must be checked regularly. Especially, when the machine is new, the rubber crawlers extend quickly due to following reasons:

- When the rubber crawlers are new, they extend quickly.
- Tightness of the rubber crawler become loose due to the sprocket fitness.

For adjusting the rubber crawler, proceed as follows:

1. Place machine on a level surface of the vehicle body.
2. Hoist up the crawler so that one side of the machines rubber crawlers can hang free and loose.

WARNING

Be careful that the machine does not fall from the hoist and is secure.

3. Loosen the crawler's lock nuts.

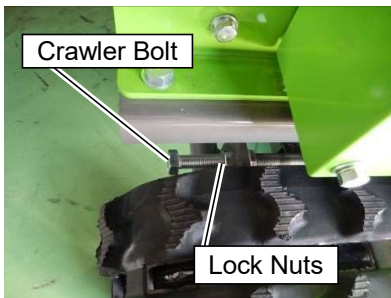

4. Turn the crawler bolt, and adjust so that the clearance between crawler and wheel (A in the illustration) is about 10-15 mm (wheels in parallel).

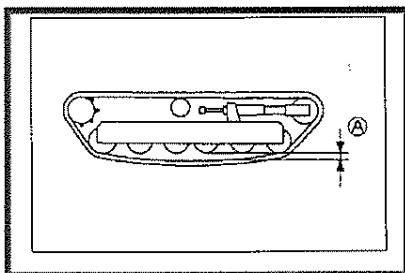

5. Tighten the lock nuts securely.

CAUTION 1

Re-tighten the crawler tension within first 10-20 hours operation.

CAUTION 2

The crawler tension on both sides should be same so that the crawler drives straight.

CAUTION 3

If the rubber crawler is not tensed correctly, life of the rubber crawler is shortened and trouble happens on the parts.

If the crawlers are tensed too much, too much friction will reduce the life of the crawlers.

The machine will also not drive efficiently.

So therefore check that the tension is correct regularly and adjust if necessary.

REGULAR MAINTENANCE

BATTERY

As shown below, remove the bolts securing the metal guide panel and the front panel and open it, to get access to the battery.

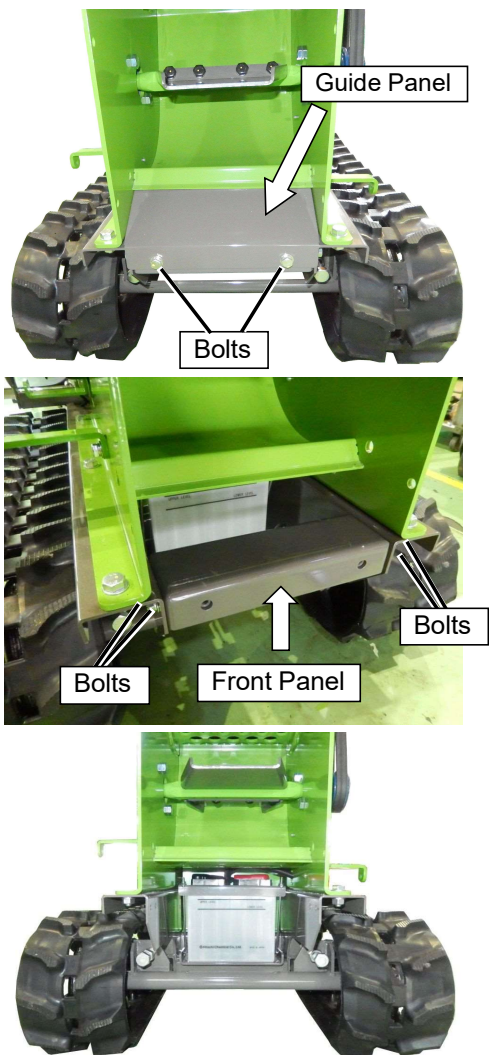

- ### DANGER
1. Keep battery away from fire.
 2. Keep battery away from children.
 3. Securely fasten cable terminal to battery.
 4. Never use corroded cable or battery terminal.
 5. Wear protective eye protectors and gloves.
 6. Be very careful. Electrolyte is sulfuric acid.
 7. If electrolyte gets in eye, take following action:
 - a) Wash eye with a lot of water.
 - b) Go to see eye doctor immediately.
 8. Never connect positive terminal and negative terminal with a metallic tool.
 9. Never use or charge battery when electrolyte level is under LOWER LEVEL.
 10. If electrolyte gets in mouth or is drunk:
 - a) Gargle with a lot of water.
 - b) Drink a lot of water or milk.
 - c) Go to see doctor immediately.

- ### WARNING
1. Never turn over, incline, drop or give shock to battery.
 2. Be careful of static electricity. Touch a metallic thing with your hand to release static electricity before use.
 3. Never clean battery with dry cloth. Use wet cloth.
 4. When replacing batteries or doing maintenance, turn off engine and remove ignition key.
 5. Replace batteries in correct way.
 6. Never connect positive and negative in reverse.
 7. Secure battery with fixing materials.
 8. Never modify or dismount battery.
 9. When electrolyte adheres to skin or clothes, flush with a lot of water.
 10. Never connect electric devices directly to battery.
 11. Never use in abnormal circumstances, like unusual odor, liquid spill and deform in shape.
 12. Never cover the 6 vent plugs.
 13. Don't add purified water more than UPPER LEVEL.

- ### CAUTION
1. Never use battery when wet.
 2. Be careful. Battery is heavy.
 3. Never replace batteries with different terminal position.
 4. Use battery in ambient temperatures of btw 15°C ~ 60°C.
 5. Never add except purified water to battery.
 6. Securely fasten vent plug after adding purified water.
 7. Place back terminal covers.
 8. Don't throw away old battery. Give it to where you buy new battery.

REGULAR MAINTENANCE

BATTERY MAINTENANCE

When doing maintenance, stop the engine and remove the ignition key.

Battery type is **34A19RT**.

- When installing / removing battery, be careful that positive and negative terminals do not touch any metallic part at the same time. If this happens, big damage will occur. Therefore at maintenance, definitely, when connecting, connect negative earth cable at the end and when disconnecting, remove negative earth cable at first.
- Always keep battery connecting parts clean and secured. If cables are loose, battery can have problems. Ensure battery terminals are covered correctly with the rubber terminal covers.
- When necessary, clean battery with soap and water. However, be careful soap and water do not get inside of battery.
- Polish terminal connecting parts with steel wool.
- Apply a thin layer of inductive silicon grease to terminals and the end of cables. It can protect against corrosion.
- When electrolyte level in battery is under LOWER LEVEL or close to LOWER LEVEL, loose 6 vent plugs and add purified water up to UPPER LEVEL. Wipe up any liquid on battery with wet cloth.

CHARGE BATTERY

- Before charging battery, remove it from chipper.
- Charge it in well-ventilated space and keep away from fire.
- Check if battery charger is OFF.
- Connect charger leads to battery. Connect positive connector of charger to positive terminal of battery and negative connector of charger to negative terminal of battery respectively.

DANGER
To prevent injury, keep distance from battery when charge is on. Damage or shortened out batteries can explode.

- Remove all vent plugs.

- Charge battery using one of the ways below. Follow the indication regards to charger in the manual provided by the battery maker:
 - Don't charge fast when engine starter doesn't rotate.
 - Specific weight of electrolyte when battery is fully charged is 1.280 times that of water at 20°C

Slow Charge	Fast Charge
14 hrs. @ 2 amps 8 hrs. @ 3.5 amps	2.5 hrs. @ 14 amps 1.5 hrs. @ 23 amps 1.0 hrs. @ 35 amps
Charge when ambient temperature is under 40°C	Charge when ambient temperature is under 50°C

- Reduce amps or temporarily stop charging when following happens:
 - Gas is emitted enormously;
 - Battery case is hot.
- Before removing charger lead from battery, definitely turn the charger "OFF".

CHANGE BATTERY

When noise produced by rotating engine starter motor is low and weak even soon after charging, it's time to change batteries. Replace battery.

- Stop the engine and remove the ignition key.
- Remove negative cable terminal.
- Remove positive cable terminal.
- Remove battery fixing materials.
- Remove battery.
- Put in new battery and secure it with fixings.
- Connect positive cable terminal to positive terminal on battery and fasten securely.
- Connect negative cable terminal to negative terminal on battery and fasten securely and apply a thin layer of inductive silicon grease to terminals and the end of cables.
- Replace terminal covers.

CAUTION

Dispose of used batteries responsibly

REGULAR MAINTENANCE

ENGINE

Please refer to the engine manufacturer's manual.

1. Engine oil change

Refer to "CHANGING ENGINE OIL"

(1) Engine oil change

After first 5 hours of operation
Every 50 hours of operation

Use high quality oil which is SF, SG, SH, SJ or higher. Outdoor temperatures determine the proper oil viscosity for the engine. Use the chart to select the best viscosity for the outdoor temperature range expected.

CAUTION

Be very careful of hot oil and avoid getting burned.

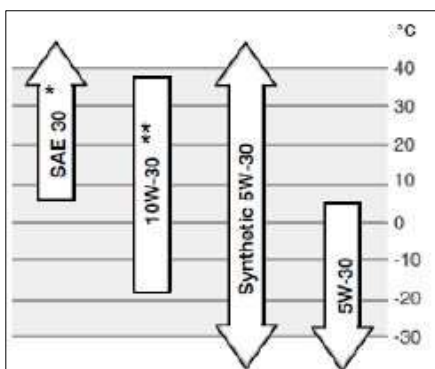

* Below 4 degrees the use of SAE 30 will result in hard starting.

** Above 27 degrees the use of 10W-30 may cause increased oil consumption. Check oil level frequently.

Remove engine oil

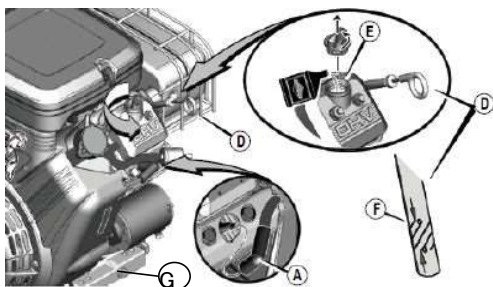

1. With engine off but still warm, disconnect the spark plug wire (A) and keep it away from the spark plug.
2. Remove the oil gauge (D). Remove the oil drain plug (G) and drain the oil into an approved container.

3. Remove the seal tape on the drain plug and apply a new seal tape.

※Wind a seal tape on the plug for 2.5 or 3 times in a clockwise direction.
(Refer to the below figure.)

※If the seal tape is not wound or wound not properly, it can cause oil leak.

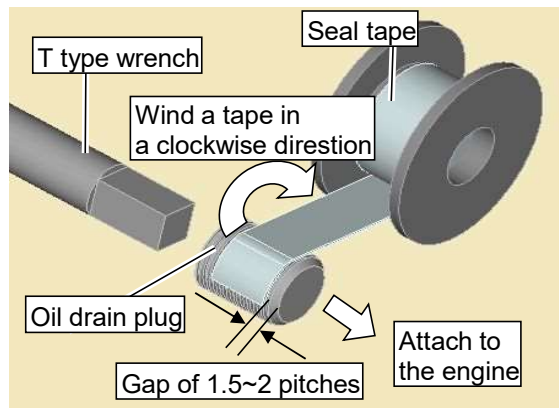

4. Replace the oil drain plug and the oil gauge.

Add engine oil

Remove the oil gauge and add the engine oil of 1.0 litre slowly.

2. Change oil filter.

It is not recommended to change oil filters when change engine oil for the first time. Change oil filters every time when change engine oil from the second time. If the engine doesn't run not more than 50 hours per year, change the filter once in a year.

When change oil filter, add oil of 1.1 litres.

REGULAR MAINTENANCE

3. Cleaning and adjusting the spark plug

- (1) If the spark plug is blackened by carbon deposit, remove the carbon deposit using plug cleaner or wire brush.
- (2) If the air gap between the center and side electrodes is not correct, bend the side electrode to adjust the air gap to 0.6~0.7 mm.
- (3) If the engine will not run even after cleaning the spark plug and adjusting the air gap, replace the old spark plug with new one.
(Champion XC92YC / Parts. No. 4910)
- (4) Install a new or re-adjust spark plug, and insert the plug cap securely.

※Change spark plug every 100 hours.

4. Change fuel filter

Change fuel filter every 400 hours or 1 year which comes earlier.

DANGER

Keep Fire Away

5. Cleaning the air cleaner

The air inlet in the cleaner is an important component that sucks in cooled air for the engine. Failure to clean regularly may lead to overheating of the engine and decrease engine power and the life of engine. Keep it clean at all times.

DANGER

Keep Fire Away

Change air cleaner paper element and pre-element every 200hours.

6. Replacing the fuel pipe

DANGER

Keep Fire Away

- (1) Replace the fuel pipe every 2 years regardless of the frequency in use. This is to prevent fuel leak due to deterioration which can cause a fire.
- (2) If you find flawed or cracked pipe that may lead to fuel leak, immediately replace it.

DANGER

Never perform any of these tasks with the engine on.

REGULAR MAINTENANCE

7. Daily check

Before driving the engine, do the check out as follows.

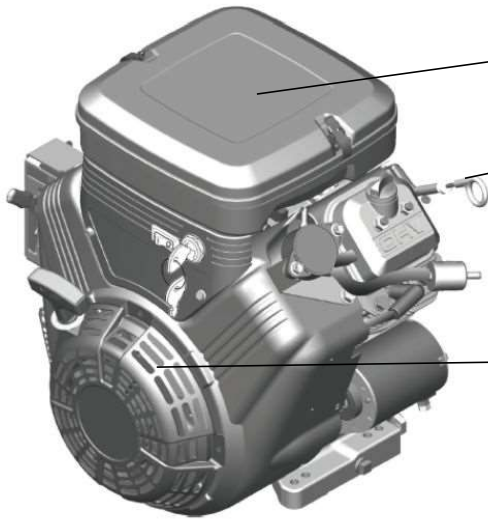

- Check cleanliness in air cleaner element.
- Check fuel level.
- Check for safety around the
- Check for unusual vibration and
- Check for loose or damaged bolts.
- Check engine oil level and
- Check for oil and fuel leaks.

8. Regular check

Time of use	8 hrs. (Daily)	50 hrs. (Weekly)	100 hrs.	250 hrs.	400 hrs.
Clean and tighten each part	● (Every day)				
Check level and clean engine oil	● (Add oil to the max. level daily)				
Change engine oil	(First 5 hrs.)	(Every 50 hrs.)			
Check muffler and control parts	●				
Clean spark plug		●			
Change spark plug			● (At proper time)		
Clean pre-cleaner		◎			
Change air filter			◎ (Every 200 hrs. or monthly)		
Change pre-cleaner			◎ (Every 200 hrs. or monthly)		
Change oil filter			◎		
Cleaning and adjusting the spark plug			●		
Check muffler and spark arrester			●		
Check and adjust bulb clearance				●	
Change fuel filter					●
Clean cooling system					◎
Clean oil cooler fin					◎

LUBRICATION CHART (Lubrication Points)

↙ Machine oil

↶ refer to picture information

↑ Lithium Grease

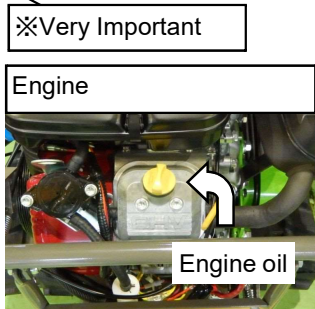
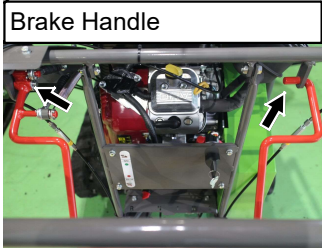
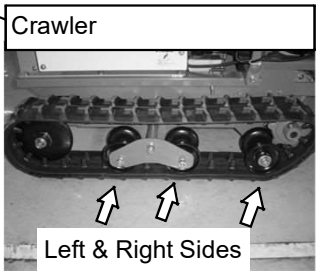
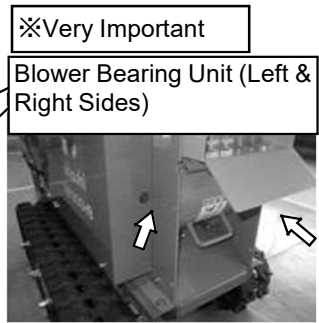

LUBRICATION CHART (Lubrication Points)



Machine oil



refer to picture information



Lithium Grease



Rotor Cover

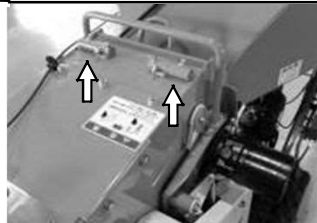

Hopper



Hydraulic Tank



※Very Important

Rotor Bearing Unit

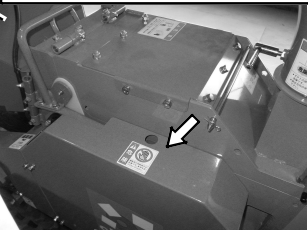

Rotor Clutch Lever

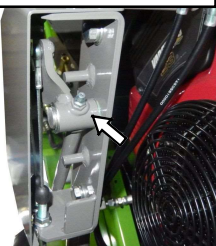

Rotor Bearing Unit



Gasoline Tank

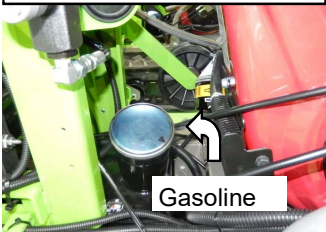





Transmission



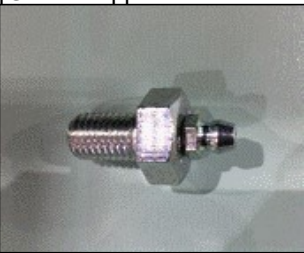

Track Roller Greasing Instructions

Every 3 months

No	Instructions	Tools	Process
1	Grease nipple bolt 		
2	Track roller fixing bolt 	H 1 7 Spanner	
3	Track roller fixing bolt removed 	H 1 7 Spanner	Use a spanner to remove the bolt
4	Grease nipple bolt installed 	H 1 7 Spanner	Use a spanner to install the grease nipple bolt.
5	Grease up 	Grease gun	Using a grease gun for first time applications, pump 5 times. For all other applications pump 3 times.

Track Roller Greasing Instructions

No	Instructions	Tools	Process
6	<p>The grease nipple bolt is removed.</p> 	H 1 7 Spanner	Use the spanner and remove the grease nipple bolt.
7	<p>Track roller fixing bolt</p> 	H 1 7 Spanner	Using the spanner affix the track roller fixing bolt to the track roller.
8	<p>Application is finished Complete steps 2~7 for all 6 track rollers to finish greasing the machines track rollers.</p>		

TIGHTENING NUTS & BOLTS

CAUTION

Before operating the machine, check if the parts are well fastened.

Engine Fixed Bolts

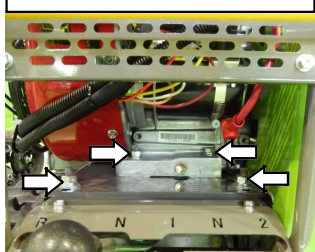

Feed Roller Arm Fixed Bolts

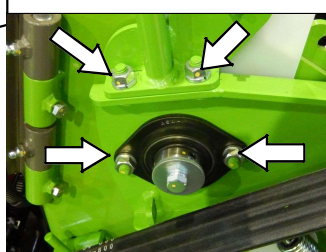

Crawler Wheel fixing bolts

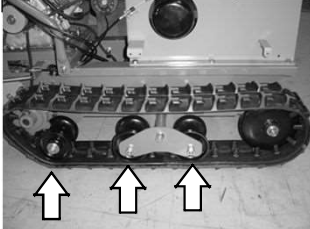

Blower Bearing Unit Fixed Nuts

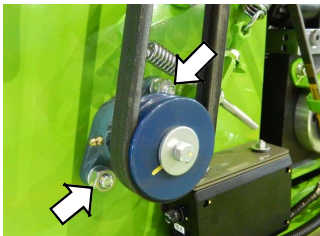

Rotor Bearing Unit Fixed

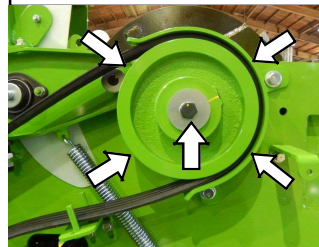

SERVICING AFTER OPERATION/LONG TERM STORAGE

SERVICING AFTER OPERATION

1. Follow the following steps to prepare for servicing and maintenance.

- (a) Shift the brake handle down.
- (b) Move the rotor clutch lever to OFF position
- (c) Turn the fuel cock to CLOSE position.

Components to clean.

(Ensure the control box beneath the rotor does not get wet with water)

- (1) Hopper
- (2) Feed rollers
- (3) Rotor housing
- (4) Rubber crawlers

CAUTION

Do not use water to clean the components near the engine, oil reservoir or electronic components. Use compressed air, a brush or cloth to clean dirt, dust and debris from these sections.

- 1. Wash the machine after use on the same day.
- 2. After washing, let the washed areas dry naturally and completely. After drying them out, lubricate the rotating and sliding parts with adequate amount of lubrication oil.
- 3. Pour oil and lubricant on and in all other parts of the machine that require it per the lubrication chart.

SERVICING AFTER OPERATION/LONG TERM STORAGE

LONG TERM STORAGE

1. Fuel

Fuel can become stale when stored over 30 days. Stale fuel causes acid and gum deposits to form in the fuel system or on essential carburetor parts. To keep fuel fresh, add a fuel stabilizer into the fuel in the tank as following.

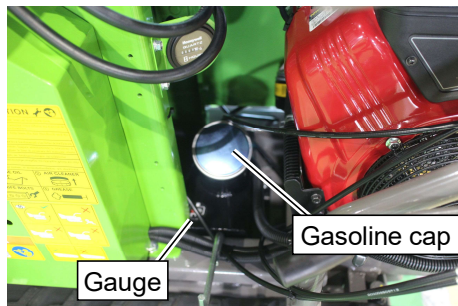

1. Remove the cap and pour the attached fuel stabilizer. Use 1 package of fuel stabilizer per 10 litres of engine.
2. Replace the cap.
3. Run the engine for 5 minutes to let the fuel stabilizer flow in the carburetor so that the engine and the fuel can be stored 24 months max.
4. Turn off the engine.
5. Close the fuel cock.

If gasoline in the engine has not been treated with a fuel stabilizer, it must be drained from the tank, the carburetor and other fuel system as following.

1. Remove the gasoline cap and remove fuel and dirt from the strainer cup.



2. Drain the fuel to a container.

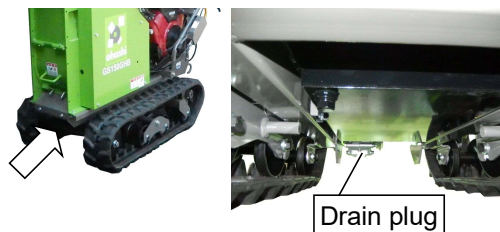

3. Replace the cap.

4. Close the fuel cock and start the engine. Run the engine until the fuel runs out.

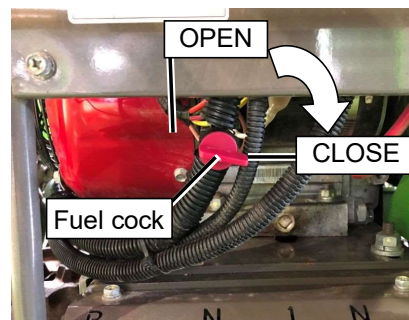

5. Turn off the engine.

SERVICING AFTER OPERATION/LONG TERM STORAGE

2. Cleaning and lubrication

1. Pour oil and lubricant on and in all other parts of the machine that require it per the lubrication chart after washing.
2. Change the engine oil.
3. Clean the element of the air cleaner and replace it.

3. Storage

Clean each components of the machine with oil cloth. Cover the machine to protect it and keep it clean. Store the machine in a clean, dry storage area.

4. Charging

Run the engine once a month and make the lubricating oil circulate in the engine and hydraulic systems and charge the battery.

CAUTION

In a cold area, mud or other obstacles stuck on the machine must be removed immediately after finishing the operation. Frozen obstacles cause machine trouble. Store the machine on the concrete or treated wood planks. If the machine would not run due to freeze, do not try to make the machine run. Use boiled water and wait until the parts could be defrosted. If the machine is moved forcibly under the above condition and machine damage happens, we the manufacturer, do not take responsibility for the damage.

ACCESSORY TOOL LIST

Check if you have all accessory tools needed.

<< Accessory tool set No. 14509900000 >>

NO	Name	Size	Qty
1	Double Ended Spanner	8 x 10	1
2	Double Ended Spanner	10 x 13	1
3	Double Ended Spanner	13 x 17	1
4	Double Ended Spanner	17 x 19	1
5	Double Ended Spanner	22 x 24	1
6	Ring Spanner	17 x 19	1
7	T type wrench	3/8	1
8	Hex Key	3 mm	1
9	Hex Key	4 mm	1
10	Hex Key	5 mm	1
11	Hex Key	6mm	1
12	Hex Key	8 mm	1
13	Plug wrench	16 mm	1
14	Cross slot screwdriver	No. 2	1
15	Pliers	150mm	1

<< Others >>

Part No.	Size	Qty
12006570001	Rotor lock pin	1
B9800150000	150mm scale	2
-	Seal tape	1

LIST OF CONSUMABLE PARTS

Spare parts	Part number	Life (per unit)	Remarks
Main Body			
Chipper knife	11106220000	300 hrs	
Chipper knife set	11106220000S	300 hrs	Knife x2, bolt x8, spring washer x8, plain washer x8, nut x8
Counter knife set	11126320000	800 hrs	Knife x1, bolt x3, spring washer x3, plain washer x3
Shredder knife set	11106250000S	200 hrs	Set includes knife x8
Rotor belt (4R-3V-800)	A813V040800	at proper time	
Hydraulic belt (SB-43)	A81SB010043	at proper time	
Transport belt (SA-38)	A81SA010038	at proper time	
Blower belt (SA-41)	A81SA010041	at proper time	2 pcs /unit
Blower fin	E14506450000	300 hrs	Fin x 1, bolt x 4
Rotor bearing unit	A7020X08000	500 hrs	Estimated life varies on usage
Blower bearing unit (UCFL204)	A7030C20400	500 hrs	
Feed roller bearing unit (right) (BPFL5)	A7055205000	1000 hrs	
Feed roller bearing unit (left) (6005ZZ)	A70600500ZZ	1000 hrs	
Engine			
Air filter	692519	200 hrs	
Air cleaner pre-cleaner	692520	200 hrs	
Fuel filter	691035	400 hrs	
Engine oil filter	842921	100 hrs	
Spark plug (Champion XC92YC)	491055S	100 hrs	2 pcs /unit
Hydraulic System			
Hydraulic hose (up)	11123510000	2 years	
Hydraulic hose (down)	11123520000	2 years	
Hydraulic hose (dial)	21123750000	2 years	2 pcs /unit, only for ES150GHB or option
Electrical System			
Battery (34A19RT)	14509610000	2 years	
Fuse A (10A) (no stress, electromagnetic valve, hour metre)	A9905212510	at proper time	
Fuse B (1A) (no stress)	A9905212501	at proper time	
Safety bar sensor	-	at proper time	

Estimated life time could vary on usage conditions.

Regarding oil change refer to oil change section of this manual.

TROUBLESHOOTING

Stop the engine before inspecting.

Problems	Probable causes	Remedial actions
Engine will not start	(1) Empty fuel tank	Add fuel
	(2) Fuel is not suctioned into the combustion chamber	Check suction carburetor and fuel strainer.
	(3) Wrong engine starting procedures	Refer to " Starting the Engine ".
	(4) Water in the fuel	If water is trapped in the fuel filter, remove the carburetor and fuel strainer to drain the water. After draining, clean the carburetor and the fuel strainer.
	(5) Deteriorated fuel retained after long term storage	Drain the old fuel in the fuel tank, fuel filter, and carburetor. Fill new fuel. In particular, check for clogged main jet of the carburetor and clean it thoroughly.
	(6) Spark plug not in working condition	Remove the spark plug. If the plug is wet, dry it over a flame or wipe it with dry cloth. Dry the spark plug thoroughly. Adjust the air gap to 0.6 to 0.7mm. If the engine will not start even after the air gap adjustment, replace the spark plug. <div style="border: 1px solid black; padding: 2px; display: inline-block; margin: 5px 0;">CAUTION</div> Replace the re-adjusted or new plug, and insert the plug cap securely.
Low engine power	(1) Dirty air cleaner	Clean the air cleaner and element with white kerosene.
	(2) Clogged engine air inlet section	Thoroughly clean the air inlet.
	(3) Low engine oil level	Refill the engine oil. If the engine oil is deteriorated, drain it and fill new oil.
	(4) Low engine speed	Reduce the play in the throttle lever. Adjust and correct the creeping of the throttle wire.
	(5) Poor compression of engine	Tighten the spark plug and cylinder head bolts. Otherwise contact your dealer to check for wear on the piston rings.
Clogging	Engine stops due to clogging of woods in the feed roller	Refer to " Feed Roller Clogging Release ".
Abnormal vibration of the machine	(1) Engine vibration due to improper mounting	Check and re-tighten the engine mounting bolts fully and securely.
	(2) Chipper knife comes off or bolts are loose	Fit the chipper knife. Re-tighten the bolts.
	(3) The rotor housing vibrates.	Re-tighten the bolts fixing the rotor housing.
	(4) The rotor shaft bearing is damaged	Replace with new one.

TROUBLESHOOTING

~FEED ROLLER CHECK~

FEED ROLLER DOES NOT ROTATE.

When the feed roller does not rotate forward:

Check points	Causes	Solutions
1) Engine power	Too low. Throttle wire loose.	Turn throttle to increase power & tighten throttle wire.
2) Feed Switch	Defective	Replace it
3) Control box wires	Defective wiring	Re-wiring
4) Hydraulic Electromagnetic Valve	Defective	Replace it
5) No stress circuit board	Broken	Replace it
6) Safety bar	Engaged or broken	Disengage or repair
7) Safety Bar Release Switch	Defective	Replace it

When the feed roller does not rotate backward:

Check points	Causes	Solutions
1) Engine power	Too low. Throttle wire loose.	Turn throttle to increase power & tighten throttle wire.
2) Feed Switch	Defective	Replace it
3) Control box wires	Defective wiring	Re-wiring
4) Hydraulic Electromagnetic Valve	Defective	Replace it
5) No stress circuit board	Broken	Replace it
6) Safety bar	Engaged or broken	Disengage or repair
7) Safety Bar Release Switch	Defective	Replace it

When the feed roller does not rotate in either direction:

Check points	Causes	Solutions
1) Fuse 10A	Defective	Replace it
2) Hydraulic belt	Broken	Replace it
3) Hydraulic belt	Too loose	Tighten the hydraulic belt
4) Hydraulic tank	Oil level low	Fill with oil
5) Hydraulic pump earthing	Not earthed	Check for too much paint or rust preventing earthing
6) Feed roller	Feed roller is clogged	Unclog per " Feed Roller Clogging Release "
7) Electric wiring	Defective wiring	Re-wiring
8) Flow controller	Is turned to very slow	Turn the dial to speed up the flow controller
9) Safety bar	Engaged or broken	Disengage or repair
10) Safety Bar Release Switch	Defective	Replace it

Automatic control does not work (The roller does not stop automatically and engine cuts out eventually)

Check points	Causes	Solutions
1) Electric wiring	Defective wiring	Re-wiring
2) Fuse 1A	Defective	Replace it
3) No stress circuit board	Broken	Replace it

Feed Mode Switch: Branch mode works but Normal mode does not

Check points	Causes	Solutions
1) Engine power	Too low	Turn throttle to increase power
2) No stress circuit board	Broken	Replace it

Feed Mode Switch: Normal mode works but Branch mode does not

Check points	Causes	Solutions
1) Feed Mode Switch	Defective	Repair or replace
2) No stress circuit board	Broken	Replace it

Safety Bar: When engaged does not stop the feed roller

Check points	Causes	Solutions
1) Safety Bar	Sensor	Adjust or replace

REGULAR MAINTENANCE

Maintenance Schedule	Daily	100 hours	200 hours	300 hours	3 months
Clean air cleaner.	✓				
Check engine and transmission oil level, cleanliness and for any spillage	✓				
Check for cracks and / or wear on the knives.	✓				
Clean engine and rubber crawlers.	✓				
Retighten the bolts of the knives.	✓				
Check fuel level.	✓				
Grease lubrication points.	✓	(Refer to "Lubrication Chart")			
Lubricate all wire and lever supporting points and any friction.	✓	(Refer to "Lubrication Chart")			
Check hydraulic system (oil, pump, tank, motor) for hose wear and cracks, oil leaks, and loose connections.	✓				
Check for cracks and / or wear of belts.	✓				
Check battery electrolyte level and terminal cleanliness.	✓				
Check rotor clutch wire adjustment.	✓				
Check robber crawler tension.	✓	(Adjust first 10-20 hrs.)			
Sharpen the chipper knives.	Every 50 hrs.				
Change engine oil.		✓(First 5 hrs. after every 50 hrs.)			
Check hydraulic oil level in tank.		✓			
Replace fuel pipe.		✓			
Clean spark plug.		✓(Every 50 hrs.)			
Clean fuel strainer				✓(Every 400hrs.)	
Sharpen the counter knife.			✓		
Replace shredder knives.			✓		
Change transmission oil.			✓(*2)		
Replace air cleaner element.			✓		
Replace chipper knives.				✓	
Change oil in hydraulic tank and pump.				✓	
Replace counter knives.	Every 800 hrs.				
Check transport clutch and parking brake.					✓
Check parking brake pad.					✓
Service engine.	(Refer to the engine manufacture's manual)				

*2 First 50 hours of use in transportation. After every 200 hours of use in transportation.

NOISE TEST

CAUTION 1

Wear ear protection at all times when using the machine.
People in close proximity to the machine should also wear ear protection to protect from ear damage.

The Guaranteed Sound Power Level for this machine was recorded at 116dB (Lwa).

The Sound Pressure Level for this machine was recorded at 88dB (Laeq).

The measurements were conducted according to:
Directive 2000/14/EC

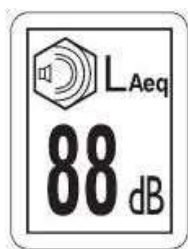

MACHINE DIMENSIONS

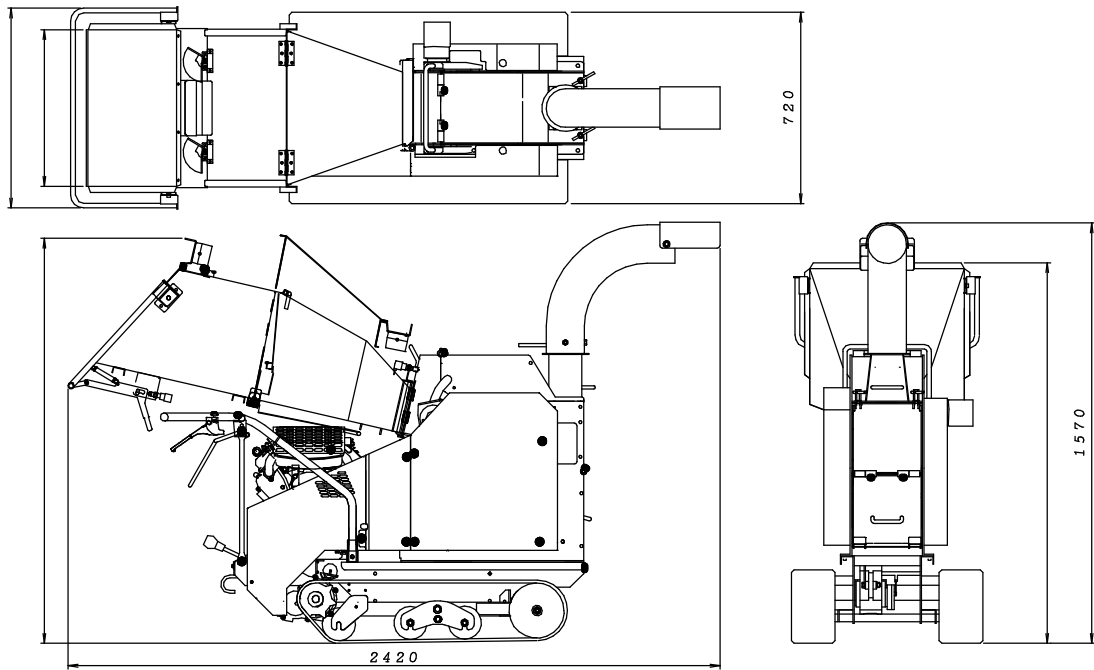

HYDRAULICS DIAGRAM

Hydraulic Pump & Hydraulic
Electromagnetic Valve & Hydraulic Tank

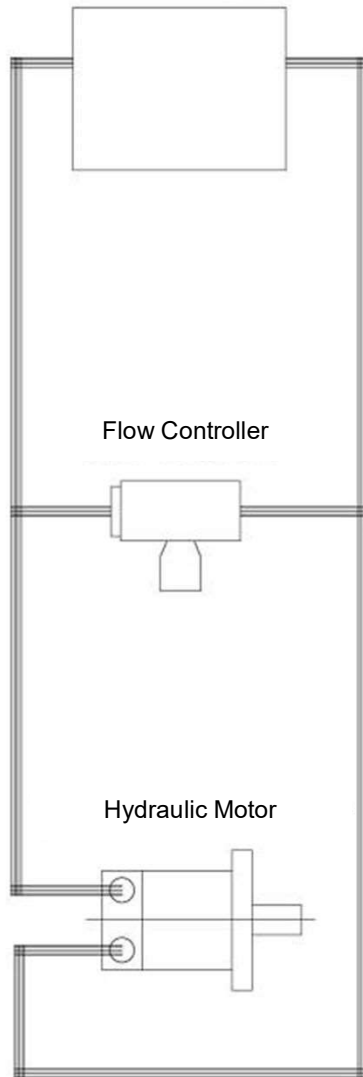

ELECTRONIC WIRING DIAGRAM

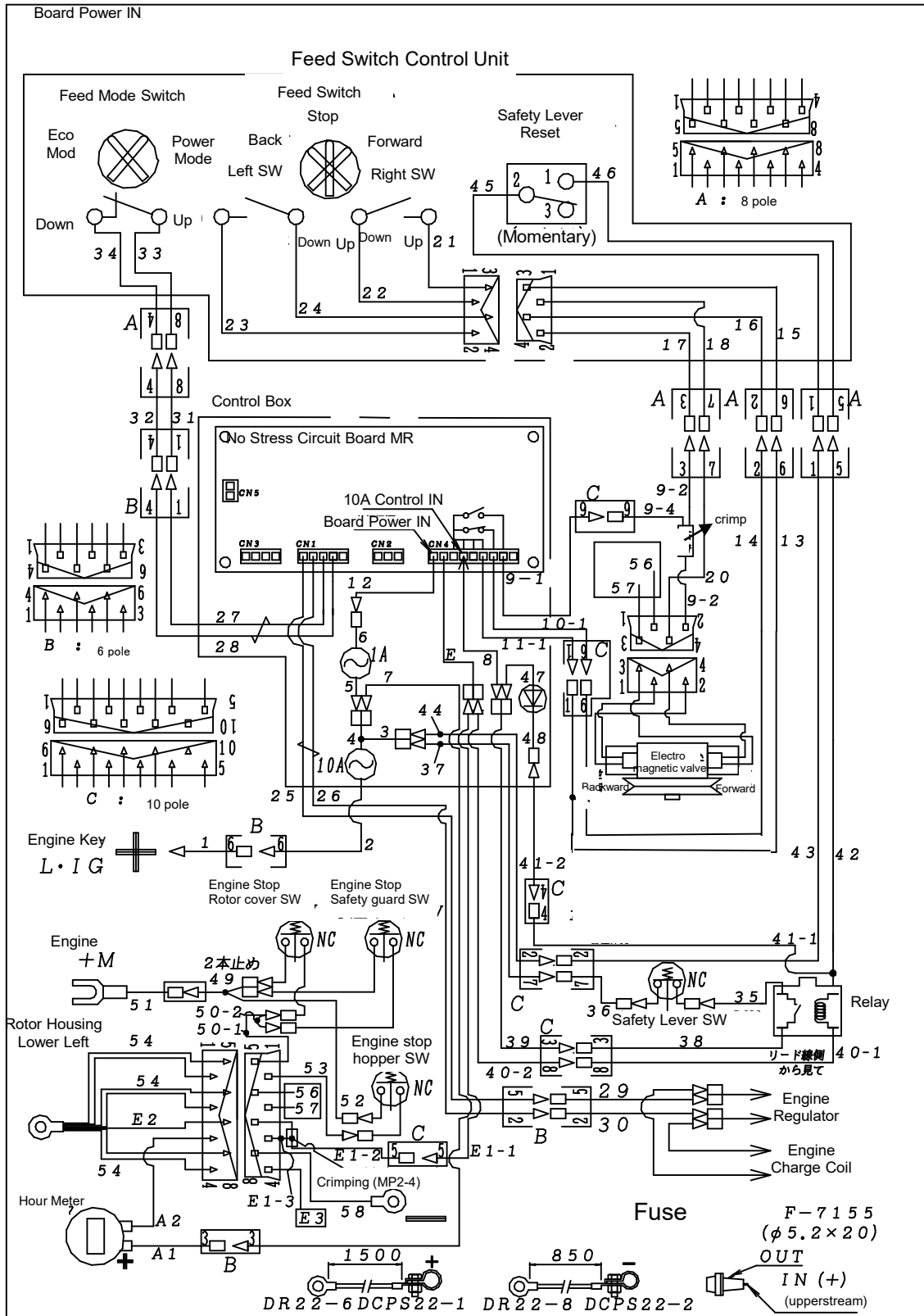

EC Declaration of Conformity

Ohashi Inc.

401 Sakimura, Chiyoda, Kanzaki, Saga 842-0065, Japan
TEL +81-952-44-3135
FAX +81-952-44-3137

We declare, under our solo responsibility, that the product:

Product: Wood Chipper

Model: ES151GH

Serial No. Range: 00101 ~ 00XXX

to which this declaration relates complies with the provisions of following European Directives:

- Directive 2006/42/EC on Machinery;
- Directive 2014/30/EU Electromagnetic compatibility Directives;
- Directive 2000/14/EC on Noise emission in the environment;
- The Guaranteed Sound Power Level for this machine was recorded at 116dB (Lwa);
- The Sound Pressure Level for this machine was recorded at 88dB (Laeq);
- Directive 2011/65/EU on the Restriction of the use of certain Hazardous;

Applied Harmonized Standards:

EN ISO 13857:2019 Safety of Machinery - Safety distances to prevent hazard zones being reached by upper and lower limbs.

EN ISO 12100:2010 Safety of machinery - general principles for design – Risk assessment and risk reduction;

EN ISO 14982:2009 Electromagnetic compatibility

EN ISO 3744:2010

EN ISO 50851:2012 Substances in electrical and electronic equipment

Authorized representative:

Mr. Thierry Fruhauff of Sapag Jardins at 2551 Chemin de Saint Claude, 06600 Antibes, France, can compile the technical file on request.

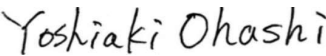
Signature: 
Yoshiaki Ohashi
President, Ohashi Inc.

Date of issue: 1 December, 2022

WARRANTY STATEMENT

The warranty period for the wood chipper commences on the date of sale to the first end user and continues for a period of 24 months. The guarantee is to the first end user only and is not transferable. However, should any damage or fault occur from a cause for which Ohashi is not responsible, then even within the aforementioned period, Ohashi will not be responsible for any warranty obligation.

The warranty is applicable only to the following:

- Machine parts which are damaged or faulty from a cause for which Ohashi is responsible, and require replacing, as well as any other machine parts which as a consequence of the aforementioned damaged or faulty parts, require replacing for the effective operation of the machine.

The warranty is not applicable to the following:

- The entire machine as a whole.
- Faults which arise due to actions / inactions that are not part of the correct and appropriate handling of the machine guidance given by Ohashi.
- Any faults or damage attributed to the handling, assembly and / or maintenance conducted on the machine.
- Any faults or damage attributed to or arising as a consequence of unauthorized modifications conducted and / or the use of parts not authorized and / or supplied by Ohashi.
- Parts which degenerate with time and use of the machine and are generally accepted to be consumable parts which require replacing at the cost of the user.
- Any faults or damage arising as a result of natural disasters or accidents and are unrelated to production errors.

Ohashi warrants to the first end user to be free from manufacturing defects both in materials and workmanship in normal service for the period mentioned above. The faulty or damaged parts should be sent to Ohashi for investigation if Ohashi requests.

JUST IN CASE OF EMERGENCY

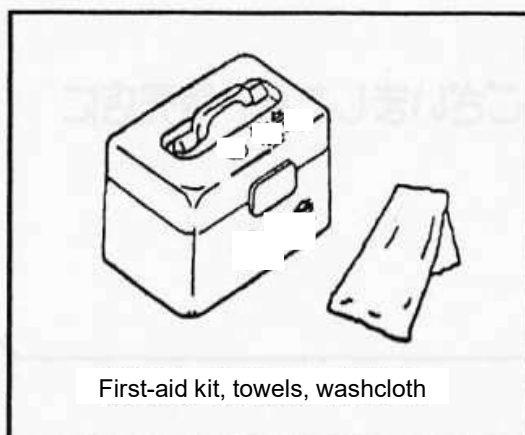
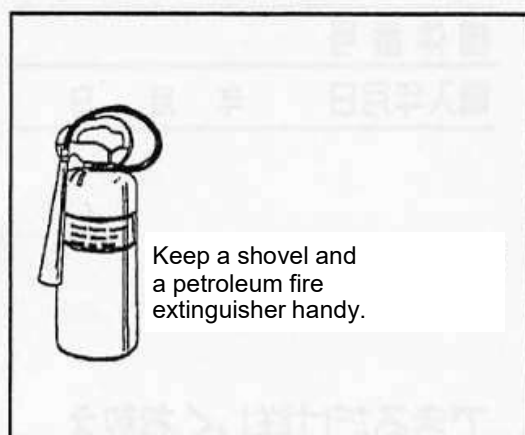
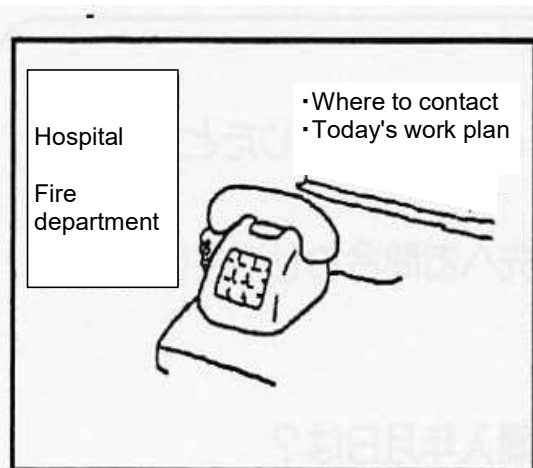

● Preparation before starting operation

- Just in case, clearly write up telephone numbers of medical institution and fire station (also to call an ambulance) in a prominent place close to telephones. In case of an emergency call, it is useful to write up a sketch map of work site (indicating address and land marks) to facilitate an emergency contact.
- Let other people know where the work is being done. Write where to contact and work plan up on the blackboard. This information will be useful should you get injured and become paralyzed being unable to call for help yourself.
- Bring a whistle to the work site.

● In case of fire

DANGER

If engine takes fire or emits smoke, stop the machine immediately and turn engine OFF. Extinguish the fire. Pay extreme caution to protect yourself from personal injury while fighting the fire.

- If engine takes fire or emits smoke from other sections than exhaust outlet, stop the machine immediately and turn engine OFF. Extinguish the fire.
- Pay extra caution to protect yourself from fire and personal injury.
- Do not let trees and grass become fuel for the fire.
- Smother the fire with sand using a shovel or extinguish the fire with petroleum fire extinguisher.

● In case of personal injury

- Just in case of personal injury, keep a first-aid kit handy. Just in case of injury involving bleeding, keep towels and wash cloth handy, which will be useful to stop the bleeding. It is advisable to always bring extra towels and washcloth to your work site just in case.

● First-aid

- To acquire fundamental knowledge and skills related to first-aid, it is recommended to take courses and trainings that are provided by local fire institution and organization.



Ohashi Inc.

401 Sakimura, Chiyoda, Kanzaki,
Saga 842-0065, Japan
JAPAN TEL : +81 952 44 3135
E-MAIL : global@ohashi-inc.com
www.ohashi-inc.com